

PCU5000-X Specification Sheet

Customer Name	Day Phone	E-Mail
---------------	-----------	--------

Kit Manufacturer		Governor Drive Ratio Rotation (facing base)	<input type="checkbox"/> 866:1 <input type="checkbox"/> 895:1 <input type="checkbox"/> 947:1 <input type="checkbox"/> 1:1 <input type="checkbox"/> Other _____ <input type="checkbox"/> Clockwise <input type="checkbox"/> Counter-Clockwise
Kit Model		Control Lever Angle (Specify)	0° to 360° (See Sketch) _____
Engine Manufacturer		Control Lever Rotation (Facing the Head)	<input type="checkbox"/> Clockwise <input type="checkbox"/> Counter-Clockwise
Engine Model		Pressure to Increase	<input type="checkbox"/> Yes For Non-Counterweighted Props
Prop Manufacturer		Pressure to Decrease	<input type="checkbox"/> Yes For Counterweighted Props
Prop Model		Take-Off RPM (Specify)	_____

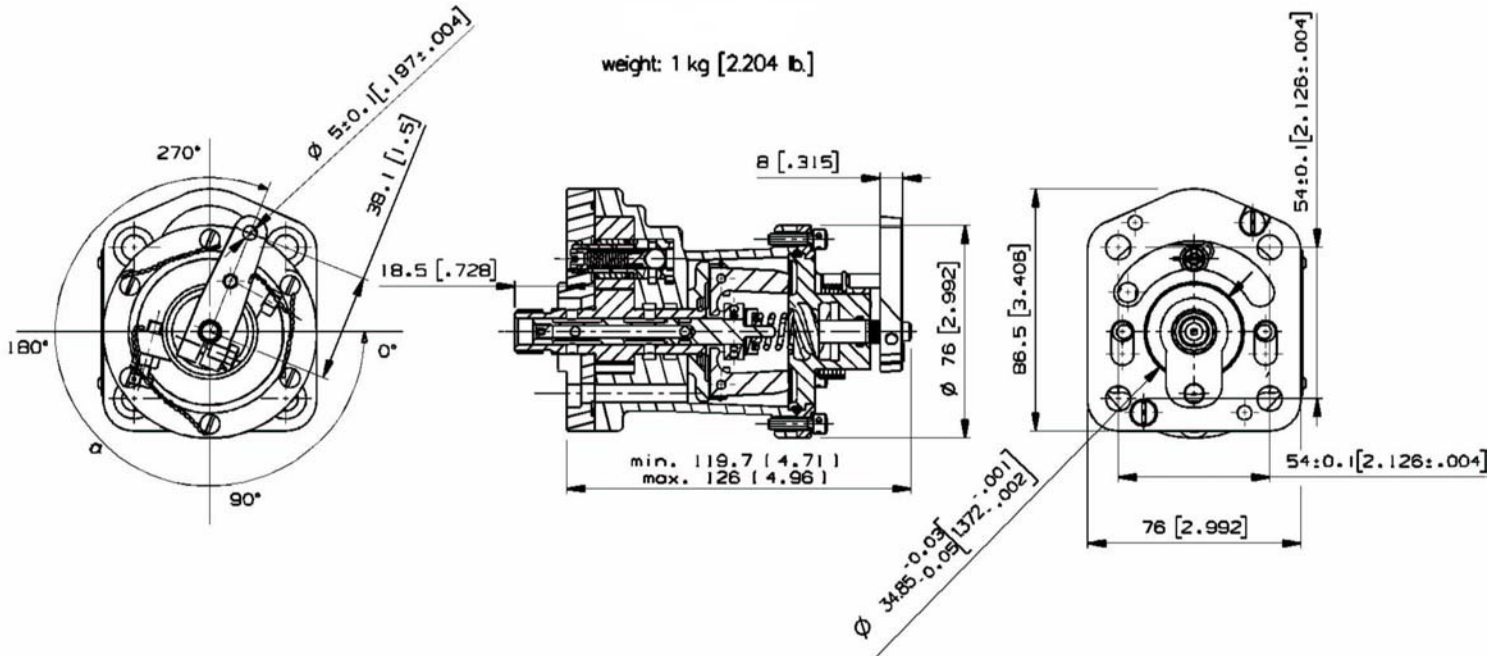

Aero Technologies, LLC