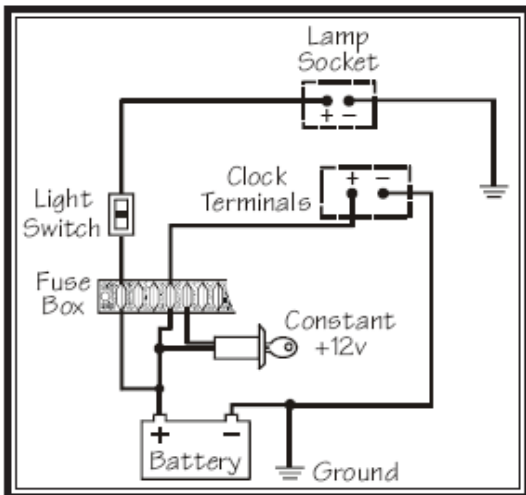

**Diagram C**  
VDO Engine Hourmeter Wiring

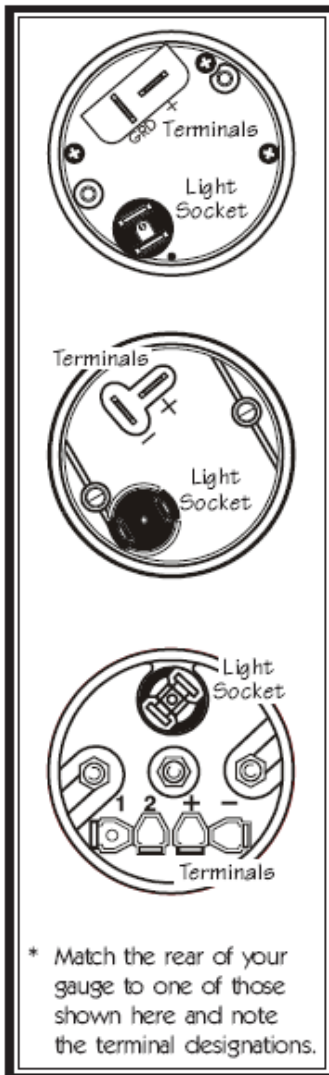

**Diagram D**  
VDO Quartz Clock Wiring

### Limited Warranty

Continental warrants all merchandise against defects in factory workmanship and materials for a period of 24 months after purchase. This warranty applies to the first retail purchaser and covers only those products exposed to normal use or service. Provisions of this warranty shall not apply to a VDO product used for a purpose for which it is not designed, or which has been altered in any way that would be detrimental to the performance or life of the product, or misapplication, misuse, negligence or accident. On any part or product found to be defective after examination by Continental, Continental will only repair or replace the merchandise through the original selling dealer. Continental assumes no responsibility for diagnosis, removal and/or installation labor, loss of vehicle use, loss of time, inconvenience or any other consequential expenses. The warranties herein are in lieu of any other expressed or implied warranties, including any implied warranty of merchantability of fitness, and any other obligation on the part of Continental, or selling dealer.

(NOTE: This is a "Limited Warranty" as defined by the Magnuson-Moss Warranty Act of 1975.)



## 1 BEGIN HERE

**CAUTION:** Read these instructions thoroughly before making installation. Do not deviate from assembly or wiring instructions. Always disconnect battery ground before making any electrical connections. If in doubt, please contact your dealer or Continental at 1-800-265-1818.

### Clock/Hourmeter Installation:

1. Select the location where you will mount the gauge, and mark a center point.
2. Cut a 2 1/16" (52 mm) diameter hole for your quartz clock/engine hourmeter. If the

### CAUTION!!!

The bezel diameter is only a few millimeters larger than the gauge itself. With that in mind, measure and precisely mark the gauge location before cutting any holes!

### Tools and Materials Needed For Installation:

- 16 Gauge stranded, insulated wire
- Non-insulated 1/4" spade connectors
- 2 1/16" hole saw
- Drill and drill bit set
- Half-round file
- Tape measure or ruler
- Small tools: wrench or nut driver, utility knife, pliers, etc.

gauge is too snug, use a file to slightly enlarge the opening. (Diagram A)

3. Slip the VDO Mounting Bracket over the back of the instrument. Properly orient the gauge in the opening, then tighten the nuts to secure the gauge in place. Tighten the bracket until the Quartz Clock/Engine Hour Meter can no longer be rotated by hand. (Diagram B)

**DO NOT OVERTIGHTEN.**

### Wiring the Quartz Clock:

1. Run wires from the Quartz Clock location through the firewall to:
  - a) the positive (+) terminal on the battery (after the fuse box, but before any switches) [Diagram C];

[text continues at #2] →

### Parts List

Item	Description	Quantity
1.	Quartz Clock and/or Engine Hourmeter (2 1/16" [52 mm] diameter)	1
2.	Lamp Socket (Push In, wedge-type)	1
3.	Light Bulb	1
4.	VDO Spin-Lok™ Mounting Bracket VDO Mounting Bracket and nuts	1 or 1
5.	Installation Instructions	1

**Continental**

Quartz Clock/Engine  
Hourmeter  
Installation Instructions  
Instruction Sheet #0 515 012 147  
Rev. 01/08

INSTRUCTIONS FOR THE INSTALLATION OF THE QUARTZ CLOCK/ENGINE HOURMETER ARE CONTAINED HEREIN. USE IS RESTRICTED TO 12-VOLT NEGATIVE GROUND ELECTRICAL SYSTEMS. LIGHT BULB, IF SUPPLIED, IS 12-VOLT.

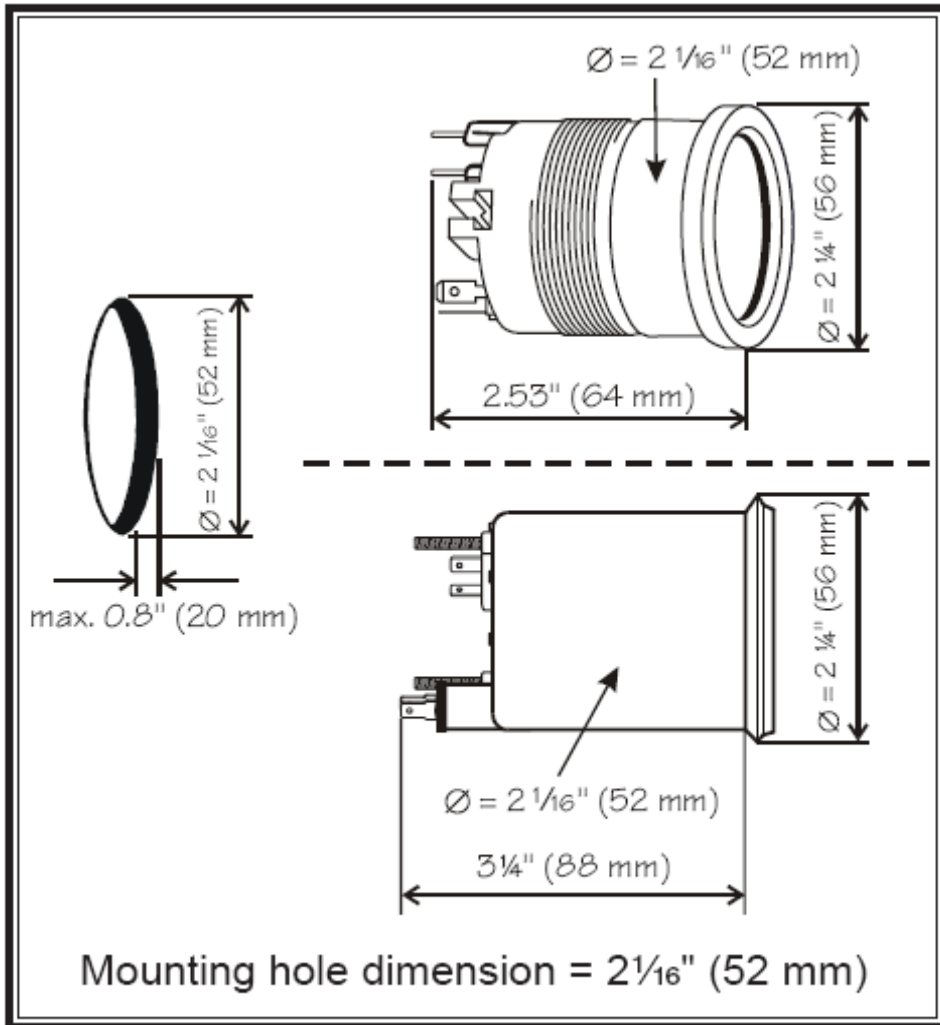

**Diagram A**  
Gauge dimensions

## 2 CONTINUE HERE

this positive power source **MUST BE UNSWITCHED**, but should be protected with a fuse);

b) the light switch (also after the fuse in the fuse box); and

c) a good ground location (i.e., anywhere you can conveniently bolt the wire to the chassis of the vehicle).

2. Connect the appropriate positive (+) and ground (negative [-]) wires to the clock and clock lamp socket as shown in Diagram D.

### Wiring the Engine Hour Meter

1. Run wires from the Engine Hour Meter location through the firewall to:

a) the positive (+) terminal on the ignition switch (after the fuse box);

b) the light switch (also after the fuse in the fuse box); and

c) a good ground location (i.e., anywhere you can conveniently bolt the wire to the chassis of the vehicle).

2. Connect the appropriate positive (+) and ground (negative [-]) wires to the Engine Hourmeter and Hourmeter lamp socket as shown in Diagram C.

At this point, the installation and wiring of your new VDO Quartz Clock/Engine Hour Meter is complete. Turn on the ignition and the lights in the car and check to see that the clock/hourmeter and light are working properly. If they are not, re-check your wiring.

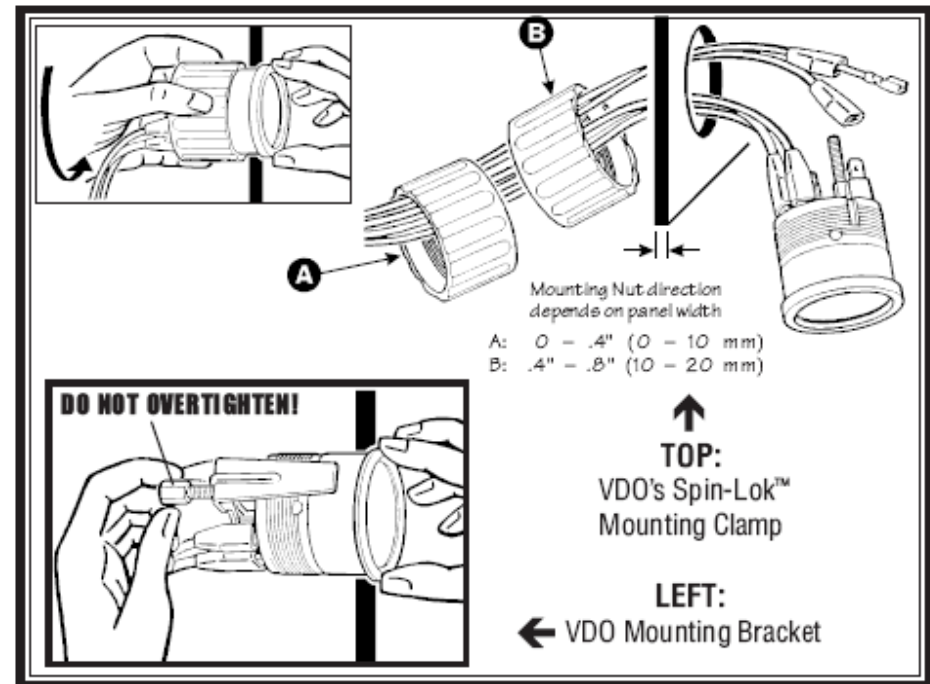

**Diagram B**  
Mounting using VDO Mounting Bracket or VDO Spin-Lok™ Clamp