

Electronic Ignition Commander



Installation and Operating Guide

Version: 2.01e
February 5, 2011

Electronic Ignition Commander

Table of Contents

	Page
Experimental – Amateur Built Aircraft Only	4
Warranty	4
Caution	4
Overview	5
Quick Start	6
Operation	7
Concept of operation	7
Timing Mark Synchronization Verification	7
Clearing a “Timing Divergence Warning”	8
Initial Timing Configuration	8
Timing Curve Configurations	8
Deleting an Active Timing Configuration	9
Setting TDC	10
TDC Verification	10
Changing Ignition Values	11
Mass Change	11
“On-the-Fly” Change	12
Making “On-The-Fly” changes:	13
Function Buttons	14
Setting Screen Brightness	15
Tachometer Functions	15
Preflight Ignition Check	16
Timers	17
Screen Flow	19
Button Labels	19
First Screen – EIC MODE	20
B1-EP CONF	21
B2-EP COMM	22
B3-EC CONF	23
B3-EC CONF → B1-LDR EPI	24
B3-EC CONF → B2-TACH MAP	25
B3-EC CONF → B3 HOBBS	26
B3-EC CONF → B4-SENSORS	27
B4-TIMERS	28
B5-OPS	29
Screen Maintenance	30
Installation & Configuration	31
Physical Installation	31
Wiring	31
Wiring configuration	32

Jumper – Pins 2 & 3	35
Connecting the EICommander to the Wiring Harness	35
Communication Configuration of the EI Commander	35
Tachometer Configuration	36
Setting the Tachometer Redline and Yellow Ranges	37
Optional Yellow Caution Alarm	37
Manifold Pressure Alarm Configuration	37
Setting the MAP Ranges	37
Hobbs Meter Configuration	38
Setting Hobbs Recording Threshold	38
Setting Hobbs Meter	38
Pulses per Revolution (PPR)	38
Dwell	39
Refresh	39
Options	39
Outside Air Temperature Sensor	40
Carburetor Temperature Sensor	40
Manifold Pressure	40
Option Configuration	42
Software Updates	43
Bootloader Wiring Harness	43
Software Downloads	44
Performing Software Updates	44
Trouble Shooting	47
Glossary / Definitions	48
Screen Definitions	51
Notes	62
2.01d Release Notes	63

Experimental – Amateur Built Aircraft Only

The Electronic Ignition Commander is not certified for aviation use and is not certified and/or approved for installation and/or use on any aircraft. It is designed and manufactured for use in aircraft certified in the "Experimental, Amateur Built" category only.

Use of this product entails certain risks; misuse can result in destruction of property, injury, including death, to you, and/or others. As the operator of this device, it is up to you to understand the dynamics of flight, engine operation, and the effect that changing ignition parameters on an internal combustion engine may have on the safe outcome of flight.

Warranty

Your Electronic Ignition Commander is warranted against manufacturer's defect for a period of one (1) year from the date of purchase.

Prior to returning any unit for service, contact EICCommander for return authorization.

Electronic Ignition Commander will repair or replace defective products within the warranty period that, in Electronic Ignition Commander's sole opinion, have not been subjected to abuse or any attempted field repairs. This warranty is limited to the purchase price of Electronic Ignition Commander hardware only and does not cover the engine or engine components that may be affected by defects or failure of the EICCommander, loss of use of the aircraft, and/or any other inconveniences or loss as a result of the failure of the EICCommander system.

CAUTION

Caution

The aircraft operator has the SOLE responsibility of determining how to appropriately and safely control engine operation. Nothing stated by Electronic Ignition Commander, its employees, owners, agents or affiliates should be construed as overriding or invalidating the engine manufacturer's instructions (including engine timing, RPM operation, warnings and limits, etc.).

Copyright © WB Repucci, LLC, All rights reserved.
8824 Glenside Street
Huntersville, NC 28078
Phone (704) 607-4572

Overview

The Electronic Ignition Commander (EICCommander) is designed to monitor and manage E-MAG Ignition's E and P 113 and 114 model electronic ignitions (EPI). Any other use is not authorized or recommended.

The EICCommander is designed to provide a pilot with information as to the status of any combination of EPI system(s) installed in their experimental aircraft. The EICCommander unit is capable of providing limited management of the E and P 113 and 114 model electronic ignitions. The EICCommander is designed to work with the standard features and functions of the EPI(s) and will not allow a user to exceed any operational limits of the EPI(s). However, safe operation within these limits is the sole responsibility of the user.

Data displayed by the Electronic Ignition Commander originates within the EPI and the EICCommander unit functions simply as a user interface to the EPI(s).

In addition to being a user interface to installed and configured EPI(s), the EICCommander has the ability to compare the timing mark of two EPIs and set an alarm condition when it identifies a possible timing divergence.

When connected to either 114 E or P model ignitions, the EICCommander can display the relative "health" of the EPI ignition. This is possible because the 114 model E and P ignitions measure the duration of the spark delivered to the cylinder. Too long of a spark duration and there is an open lead or broken wire. Too short of a spark duration and there is a short or fouled spark plug.

The EICCommander can manage one or two EPIs. Regardless of how many EPIs are installed and connected to the EICCommander, the EICCommander must be configured to communicate with two EPIs or one on either the left or right channels.

For some operations, it may be desirable to change the configuration to communicate with only one EPI vs. both. Changes may be performed at any time. Typically, once the configuration is set, it does not need to be changed unless an EPI is added or removed.

Note: All screen images displayed in this manual are facsimiles of the actual screens.

Quick Start

Prior to use, the EICommander must be connected and configured to operate in the aircraft in which it is installed. See the following sections at the back of this manual for installation and setup instructions:

	Page
Wiring	31
Communication Configuration of the EI Commander	35
Tachometer Configuration	36
Hobbs Meter Configuration	38
Pulses per Revolution (PPR)	38

Operation

Concept of operation

Two EPIs and the EICommander are essentially three independent systems that are capable of communicating and exchanging data. While a single EPI can be used, several features of the EICommander are not available when using one EPI. The Timing Divergence Warning capability requires two EPIs and the EICommander must be configured for dual EPIs for this warning routine to function, thus this warning capability is only available when two EPIs are installed and configured.

The number one priority of the E and P model ignitions is to fire the sparkplugs at the correct time, every time. Thus, there will be occasions when the EICommander will try to either retrieve or send data to the EPI(s) and the EPI(s) will not respond. The EICommander has been optimized to work around this asynchronous communications issue; however, the importance of firing the sparkplugs is paramount, thus there may be occasions when a given command must be repeated.

Timing Mark Synchronization Verification

When the EICommander is installed on an engine with any combination of E or P model electronic ignitions from E-MAG Ignitions the EICommander will automatically monitor when each EPI fires and will display a “Timing Divergence Alarm” (TDA) when the following criteria are met: The EICommander is configured to dual EPIs, the engine is operating above 900 RPMs, either the Tachometer or Hobbs mode screens are displayed, and the TDA is active.

Should the timing difference between two EPIs become greater than six (6) degrees, the EICommander will display the following “Timing Divergence Alarm” and flash its red LED. Simultaneously press buttons **B1** and **B4** to toggle from the TDA warning screen to the **Timing Divergence** screen.

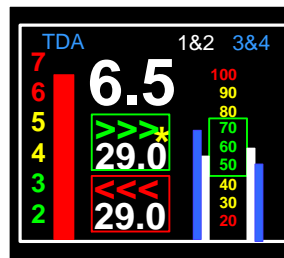

A timing divergence might occur if one EPI's Top Dead Center (TDC) value is set differently than the other or if the fasteners holding one EPI become loose and allow that unit to turn/slip. See the “Trouble Shooting” section for a list of additional possible causes for the TDA alarm.

Setting the constellation shift of one EPI such that the timing difference between two EPIs is greater than six (6) degrees will trigger a TDA warning.

- Note:
1. This function only operates when the EICommander is connected to and configured for two operational EPIs.
 2. Should the connection to one EPI fail (broken wire, bad connection, etc.) the EICommander will assume the timing is in error and will issue a TDA warning.

Clearing a “Timing Divergence Warning”

Press the **B1** and **B4** buttons simultaneously in the Operation Mode screen to clear the “Timing Divergence Alarm” (TDA). Once the **B1** and **B4** buttons are depressed, the TDA alarm is “cleared” and the TDA screen is displayed. In addition, the TDW is no longer “Armed”. A red “A” with a circle with a slash  will be displayed in the upper right hand corner of the Tachometer screen indicating the TDW is not “Armed”.

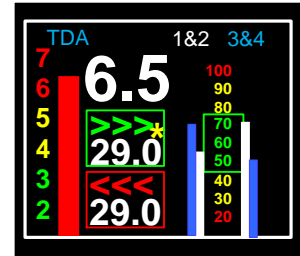

To rearm the TDW message, press the **B1** and **B4** buttons simultaneously. This will remove the symbol from the Tachometer screen, indicating the “Timing Divergence Warning” is armed. The operational status of the TDA may be verified by pressing button **B1** to display the Tachometer screen.



Initial Timing Configuration

When the EICommander is first installed, connected to EPI(s), and powered on it will have no impact on the configuration of the ignition(s). Thus, it is possible that in a new EICommander installation, the removal of a jumper between pins 2 and 3 on the EPI(s) will force the timing shift to switch to the “B” curve, as described in the E-mag Electronic Ignition manual.

Timing Curve Configurations

The EICommander provides the ability to maintain and manage five (5) different timing configurations.

A Config – Same as defined in the E-MAG Ignition Installation and Operating Guide

(Defaults: RPM: 3072, Advance Max 35.0, Adv Shift 0.0, RMSD 0, LED 1,)

B Config – Same as defined in the E-MAG Ignition Installation and Operating Guide except the maximum RPM may be reduced to 2560.

C Config – User defined
D Config – User defined
E Config – User defined

Changes to Configurations A and B are limited to reducing the maximum advance and maximum RPM.

Config A: Maximum advance is 33.6 degrees and maximum RPM is 3072. The curve shift is set to 0 and cannot be changed.

Config B: Maximum advance is 35 degrees and maximum RPM is 3072. The curve shift is set to 4.2 but can be reduced to -12.6.

Config C: Pre-configured to match the A configuration. The RPM limit can be raised to 3328. The maximum advance can be set to any value between 19.6 and 46.2, inclusive. The constellation shift can be set to any value between -12.6 and + 12.6, inclusive.

Config D: Not preconfigured but are initialized with the default A configuration settings. Limits are the same as “Config C”.

Config E: Not preconfigured but is initialized or overwritten whenever **B2-Retain** is pressed while making an “**On-The-Fly**” change. The configuration is named “***TMP**”. If no “**On-The-Fly**” changes are made, this configuration can be set and utilized in the same manner as configurations C & D. Limits are the same as “Config C”.

Configuration C, D, and E may be renamed, as desired. Configuration names are limited to three (3) characters.

Notes: 1. The EPI responds to changes in RPM in increments of 256. Therefore, the RPM will increment/decrement by 256 RPM intervals.
2. Changes to ignition timing will increment/decrement in steps of 1.4 deg. For example, if the timing offset started at 0, pressing the B3 button once would increase it 1.4 degrees. Pressing it twice would increase it by 2.8 degrees, etc.

Deleting an Active Timing Configuration

Timing configurations A and B cannot be deleted. Timing configurations C, D, and E may be deleted but only when they are not the configuration in use. (The active configuration is identified by the green “>” pointer on the **EPI Config** screen.

Timing configurations may be deleted if they are not active. If the timing configuration to be deleted is active, select an inactive timing configuration and send it to the EPI(s).

The button sequence to delete a timing configuration is:

B1-CONF → **B2-EIC>EPI** → select the configuration to be deleted → **B5** → **B2-DELETE**.

Setting TDC

It is not possible to set ignition timing (Top Dead Center or TDC) via the EICommander. It is important to cycle the power to the EPI(s) prior to setting the ignition timing. This is required to reset any possible configuration settings that may not have been saved to the EPI memory.

Refer to the E-MAG Ignition Installation and Operating Guide for details.

TDC Verification

The steps listed below will display the current EPI timing on the EICommander. This is useful for verifying the correct EPI timing configuration. It is recommended that the TDC is verified after the initial installation and following any maintenance on the aircraft's ignition system(s).

1. With the engine shut down, turn off both ignitions, even if only one EPI is installed.

WARNING

2. Verify both ignitions are turned off and not operating before proceeding. Injury or death may occur, if either ignition fires.
3. Set the engine to TDC.
4. It is important that Top Dead Center is used and not 25 degrees before TDC as is normal for traditional magnetos.
5. There is a timing mark on the back of the flywheel, align the TDC / zero mark with the engine case split line.
6. Apply power to the EPI(s) and the EICommander.
7. Press **B1-EIC<EPI** to acquire the EPI static data.
8. Press **B3** to display the third **Static Data** screen.

The current firing angle of the EPI ignition(s) will be displayed in the box labeled **PROPdeg**. These numbers should be close to zero (0). Due to gear lash, it is not uncommon to see numbers that are two or three degrees different.

Note: It is suggested a small mark be placed on the spinner which aligns with a cowl part line when the engine is at Top Dead Center. This will allow the operator to set the engine to TDC and verify the timing from the EICommander without removing the cowling.

Changing Ignition Values

There are two ways to make changes to the ignition values; “**Mass Change**” and “**On-the-Fly**”. **Mass Changes** are predefined ignition settings that are sent to the EPI(s) en mass. **On-the-Fly** changes are performed on one EPI at a time, such as when defining new ignition settings. The ignition values may be changed with the engine running or shut down.

Care should be taken when changing ignition values. Incorrect ignition values could damage your engine causing engine stoppage which may result in destruction of property, injury, and/or death. It is up to you, as the pilot, to determine the safe operational parameters for your ignition/engine installation and operational environment.

WARNING

Mass Change

Pushes a predefined ignition configuration (Configurations A, B, C, D, or E) to all installed and selected EPIs.

Care must be taken when pushing a new configuration to the aircraft’s ignition. It is advisable to utilize only configurations that have been tested and found to present no undesirable operational issues.

The **EPI CONFIG** screen provides the means to select, create, change, and delete timing configurations within the EICommander. Only stored configurations may be uploaded to both EPIs simultaneously. It is up to the pilot to determine if a configuration stored within the EICommander is suitable for flight.

1. Navigate to the **EPI CONFIG** screen and press **B2-EIC>EPI** (EICommander to EPI).
2. Arrow up and down by using buttons B1 (up) and B3 (down) to select the desired configuration. The text of the selected configuration will change from yellow to white.
3. Press button **B5** to select the highlighted configuration.
4. The selected configuration will be presented for review. Values may be changed, if desired.
5. Press button **B5** to switch to the **CONF ACTION** screen.
6. If changes were made, press **B1-SAVE>EIC** to save the updates to the EICommander.
7. If the newly saved configuration is to be sent to the EPIs, it must be reacquired (reloaded) by pressing button **B2** “EIC>EPI”. Select the recently

- saved configuration. After reviewing the configuration, press **B5** to go to the **Conf Action** screen
8. Activate a configuration by pressing button **B3-SEND>EPI** to it the ignition(s). The ignition(s) will be updated based on the previously selected configurations (left/right/dual). After the update is performed, the EICommander will return to the **CONF ACTION** screen.
 9. To remove a selected configuration from the EICommander's memory, press button **B2-DELETE**.
 10. Press **B5-ABORT** to return to the **EPI CONFIG** screen.

- Notes:
1. If changes are made to a configuration, they must be saved prior to being sent to the EPIs.
 2. When creating a new configuration, the EICommander will require the entry of a configuration name. Configuration names may contain up to three characters.
 3. An asterisk (*) immediately to the left of a configuration name indicates the configuration has been initialized.
 4. A green greater than sign (>) to the left of a configuration name indicates that configuration is currently active.

WARNING

“On-the-Fly” Change

“On-the-Fly” changes are designed to allow for ignition tuning while the engine is running. This is an advanced feature and care should be taken to reduce the risk to the aircraft, pilot, and passengers. The changing of ignition timing parameters while flying is inherently risky and is NOT recommended.

CAUTION

CAUTION: “On-the-Fly” changes are immediately transmitted to the selected EPI as the Increase (B3) and Decrease (B4) buttons are pressed. For your safety, it is imperative to increment / decrement each setting one step at a time, observe and evaluate the results for satisfactory engine operation prior to making additional changes to the active setting. For example, it would NOT be wise to operate the engine with a constellation shift of 0 degrees ignition timing and then to suddenly command the EPI to shift the timing curve by +12.6 degrees. It is possible that that such a change may not be suited to the engine's operating regime.

Due to the risks involved with adjusting the timing configuration of a running engine, the following parameters are enforced:

1. Only one ignition at a time may be modified in this mode
2. The active configuration may not be modified

3. Only the following three parameters may be changed:
 - a. Maximum RPM limit
 - b. Maximum Advance Limit
 - c. Advance Curve Shift

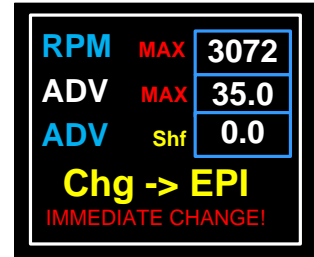

- Notes:
1. The EPI responds to changes in RPM in steps of 256 RPM. Therefore, the RPM will increment/decrement by 256 intervals.
 2. Changes to ignition timing will increment/decrement in steps of 1.4 deg. For example, if the timing offset started at 0, pressing the B3 button once would increase it 1.4 degrees. Pressing it twice would increase it to 2.8 degrees, etc.
 3. The EIC allows for a negative shift. This is provided for engines with a forced induction system.

WARNING

Making “On-The-Fly” changes:

1. Upload an inactive configuration. (The following steps will use configuration “C” for demonstration purposes.) Using the **EPI CONF** function, load configuration “C” to one or both of your EPIs.

- Notes:
1. Configurations “A” and “B” may not be modified by the “On-The-Fly” function.
 2. It is recommended that the configuration to be modified should be loaded to the EPI(s) prior to engine start, in anticipation of **On-the-Fly** changes.
 3. It is recommended that changes should be made to only one EPI at a time with the second EPI turned off. This keeps the second EPI from masking the changes made and allows the pilot to turn on the unchanged EPI and turn off the modified EPI, should a setting be entered that could compromise continued engine operation. See the section on selecting Left / Right / Dual EPIs.
 4. After a configuration has been satisfactorily tested on one EPI, the configuration can be saved to the EICOMMANDER and sent to both EPIs or using this function, the other EPI can be brought on line and adjusted manually.

2. Then using procedures described above, from the **EPI CONF** screen, select and send configuration “C” to the selected EPI.
3. Return to the **EIC Mode** screen and select **B2-EP COMM**. Notice that if one EPI had previously been selected the **EPI COMM** screen with the two choices will not be displayed. The screen to select Left / Right / Dual will only appear if the current communication configuration is set to Dual.
4. The EICOMMANDER will retrieve and display the current settings from the EPI. The first screen displayed contains the static data and the second screen will display the real-time streaming data of total advance, RPM, volts,

- temperature, and ignition coil status. The labels will be in green to signify it is streaming data from the EPIs. Recall that only three EPI parameters may be changed in this mode; Max RPM, Max Advance, and Advance Shift.
5. Once both screens have been displayed and populated, press buttons **B1**, **B2**, and **B4** to switch between the screens.
 6. Pressing button **B3** while one of the two screens is displayed will take you to the **IMMEDIATE CHANGE** screen.
 7. The “**IMMEDIATE CHANGE**” screen will display the following three parameters:
 - a. RPMmax
 - b. ADVmax
 - c. ADVshf
 8. Use buttons **B1** (up) and **B3** (down) to select the parameter to change. The label will turn from blue to white indicating which parameter is selected.
 9. Press **B2** (increase) and **B4** (decrease) to set the selected values.
 10. After changing any value, press **B5** to retrieve the updated data from the EPI to verify the desired change(s) occurred.
 - i. **Check engine gauges** after making any ignition changes to verify safe engine operation.
 - ii. Although these changes have been sent to the EPI, they are not stored in the permanent memory within the EPI. Powering down the EPI will clear the new settings.
 11. Press **B5** to exit to the “**DISPLAY**” screen.
 12. Press **B5** to exit to the “**FUNCTION**” screen.
 13. Press **B2-ConfSave** to save the current setting to the EICommander’s memory. This displays a two column screen; “old” values on the left and “new” values on the right.
 14. Press **B5** to display the **CONF ACTION** screen.
 15. Select one of the three options from the **CONF ACTION** screen listed below:
 - a. **B1-TEMP** – Retains the modified configuration until the EPI is powered down. Upon EPI power down, the EPI return to its last saved configuration.
 - b. **B2-RETAIN** – Stores the modified configuration in the EPI’s permanent memory and in the last configuration position within the EIC with the name “*TMP” which becomes the current configuration. Upon EPI power down and power up, the modified configuration will be active.
 - c. **B3-A CONF** – Reset the EPI to the “**A Config**”. This is to be used in the event an undesirable timing configuration was configured on the EPI. Prior settings will be lost.
 - d. **B5-Exit** – Exit and return to the **FUNCTION** screen.
 - e. **B5-Exit** – Exit and return to the **EIC MODE** screen.

Function Buttons

The buttons, labeled B1 through B6, provide a number of functions depending on the screen displayed. See Screen Flow diagrams for details.

When a screen is displayed with multiple values that may be changed, the following button functions will be active:

- B1** – Move up one field
- B2** – Move down one field
- B3** – Increase the displayed value
- B4** – Decrease the displayed value
- B5** – Exit current screen, move back one level
- B6** – Reset the EICommander and return to the top logo screen

On all other screens, the buttons operate as labeled.

Setting Screen Brightness

With the Tachometer displayed, press buttons **B2** and **B3** simultaneously to cycle through the **BRIGHT**, **MEDIUM**, and **LOW** screen brightness settings.

The screen brightness will return to **BRIGHT** after the EICommander is either reset or powered off and back on.

Tachometer Functions

The EICommander tachometer function operates similar to an analog tachometer. Rather than having a bezel with painted yellow and red ranges the EICommander can be configured with two yellow ranges and fixed redline.

When operating in a caution range, a yellow triangle  will be displayed above the Tachometer number.

When operating in the warning range, a red triangle  will be displayed above the Tachometer number.

The RPM's will always be displayed in white numbers for clarity. As depicted in the image on the right. If the MAP option is activated, the “Electronic Ignition Commander” text will be replaced with a small logo and the MAP pressure box will be displayed directly above the RPM's.

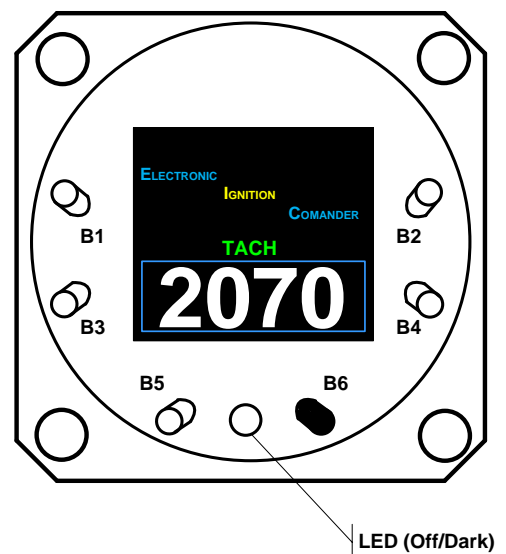

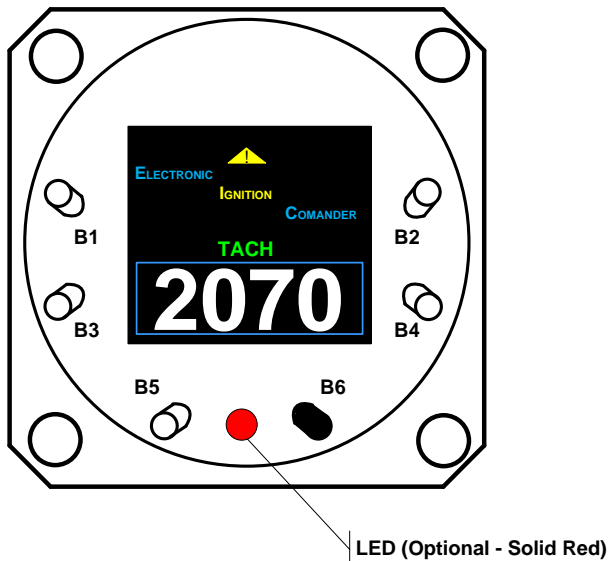

When operating in a yellow or warning range, a yellow triangle will be displayed above the RPM number yellow. The LED light, located between buttons B5 and B5 can optionally be configured to turn solid red.

When the engine speed (RPM) reaches the maximum allowable limit (Red line) set in the configuration screen a red triangle will be displayed above the RPM number and the LED will flash.

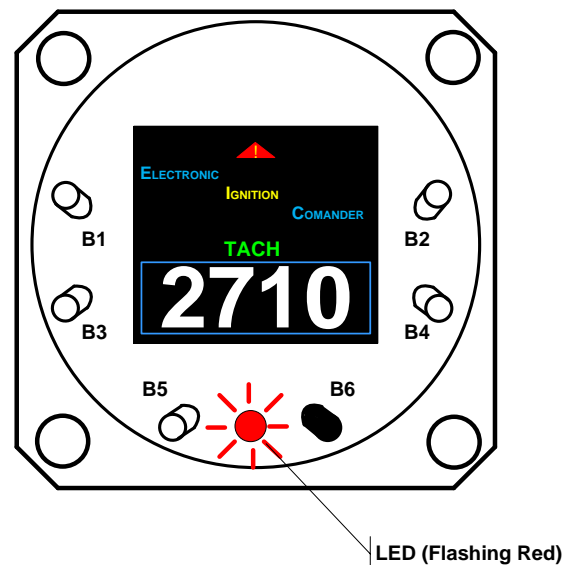

Preflight Ignition Check

Prior to flight, it is possible to verify the timing divergence when more than one EPI is installed. If 114 series E or P model ignitions are installed, the EICOMMANDER can report the relative health of the ignition harness(es).

While in the Tach Display screen (**B5-OPS**), press **B3** to display the TDA screen.

The TDA screen may be displayed at any time prior to flight, during flight, or after flight.

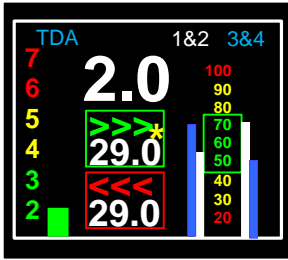

Preflight Image 1

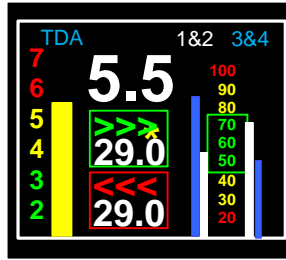

Preflight Image 2

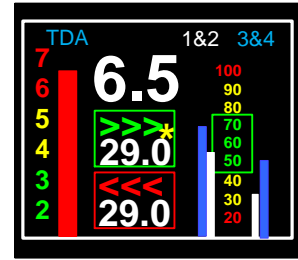

Preflight Image 3

Preflight Image 1: The timing difference between the two installed EPIs is 2.9 degrees, the current advance for both EPIs is 29.0 degrees, and the coil packs one and two on both the left and right EPIs indicate that the condition of the ignition harness and sparkplugs are within tolerance.

Preflight Image 2: The timing divergence is 5.5 degrees and is in the yellow caution range. The ignition timing discrepancy should be addressed prior to flight. The current advance for both EPIs is 29.0 degrees. The plugs and ignition wires connected to the left EPI and firing cylinders three and four (3&4) should be inspected for a possible loose/broken wire, disconnected and/or defective plug.

Preflight Image 3: The timing divergence is out of limits and corrective action should be taken prior to flight. The condition of the wiring harness for the right EPI is questionable and should be inspected. The right ignition harness and plugs firing cylinders one and two (1&2) should be inspected for a short or fouled plug.

WARNING

The EPI is not capable of determining if the timing is set properly in relation to the engine's Top Dead Center. It is only capable of comparing the difference in timing of two EPIs. While unlikely, it is possible that both EPIs timing could slip out of specification by the same amount at the same time. In the event this occurs, it is up to the pilot to recognize this condition and take the appropriate action prior to flight or terminate the flight immediately.

Timers

In addition to the Hobbs meter, the EICommander has three other timers. The first being an Event Timer (ET), this timer is used to count down to some repetitive event, such as a reminder to switch fuel tanks after "X" number of minutes of flight.

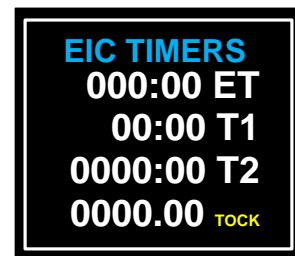

The second and third timers, T1 and T2, are similar to an automotive trip odometer. T1 is used to time the last leg since engine startup and T2 counts the time since trip reset. This allows the pilot to track total trip time as well as leg time.

The fourth time displayed is the Hobbs time.

The time displayed for the ET, T1, and T2 timers are in hours and minutes while the Hobbs time is displayed in hours and 1/10ths of an hour.

To set the event timer, from the **EIC MODE** screen press **B4-TIMERS**, **B1-Event Tmr**, and then press **B2-Increase** or **B4-Decrease** to set the duration of the event timer in minutes. When finished, press **B5-Save/Exi** to save the timer duration and exit the screen.

When changing a value, pressing buttons **B2** or **B4** once will increase or decrease the value one unit at a time. Holding either button down will cause the rate of change to “accelerate”. Releasing the button and pressing it again, will revert to the slower rate of change.

Screen Flow

Button Labels

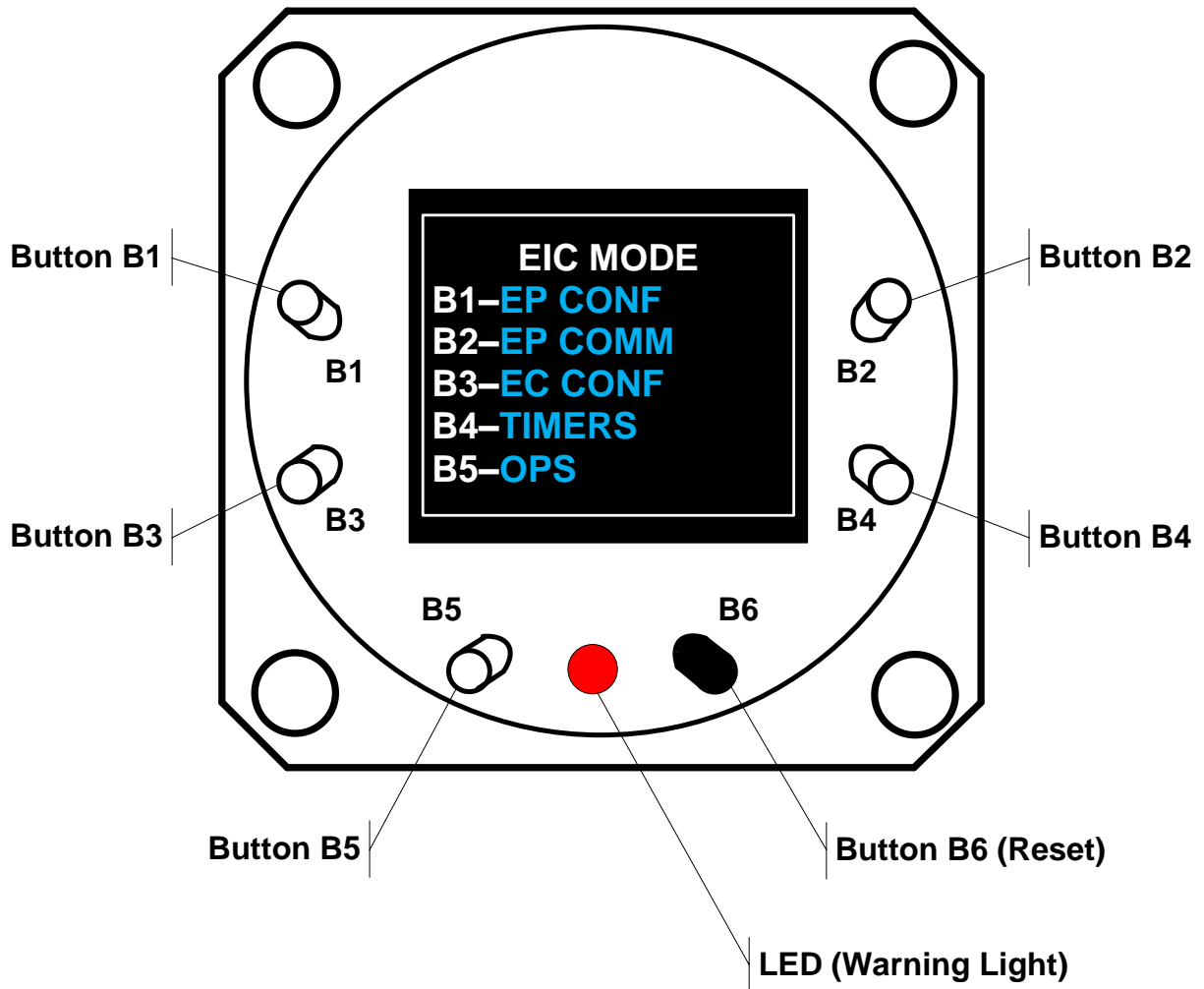

First Screen – EIC MODE

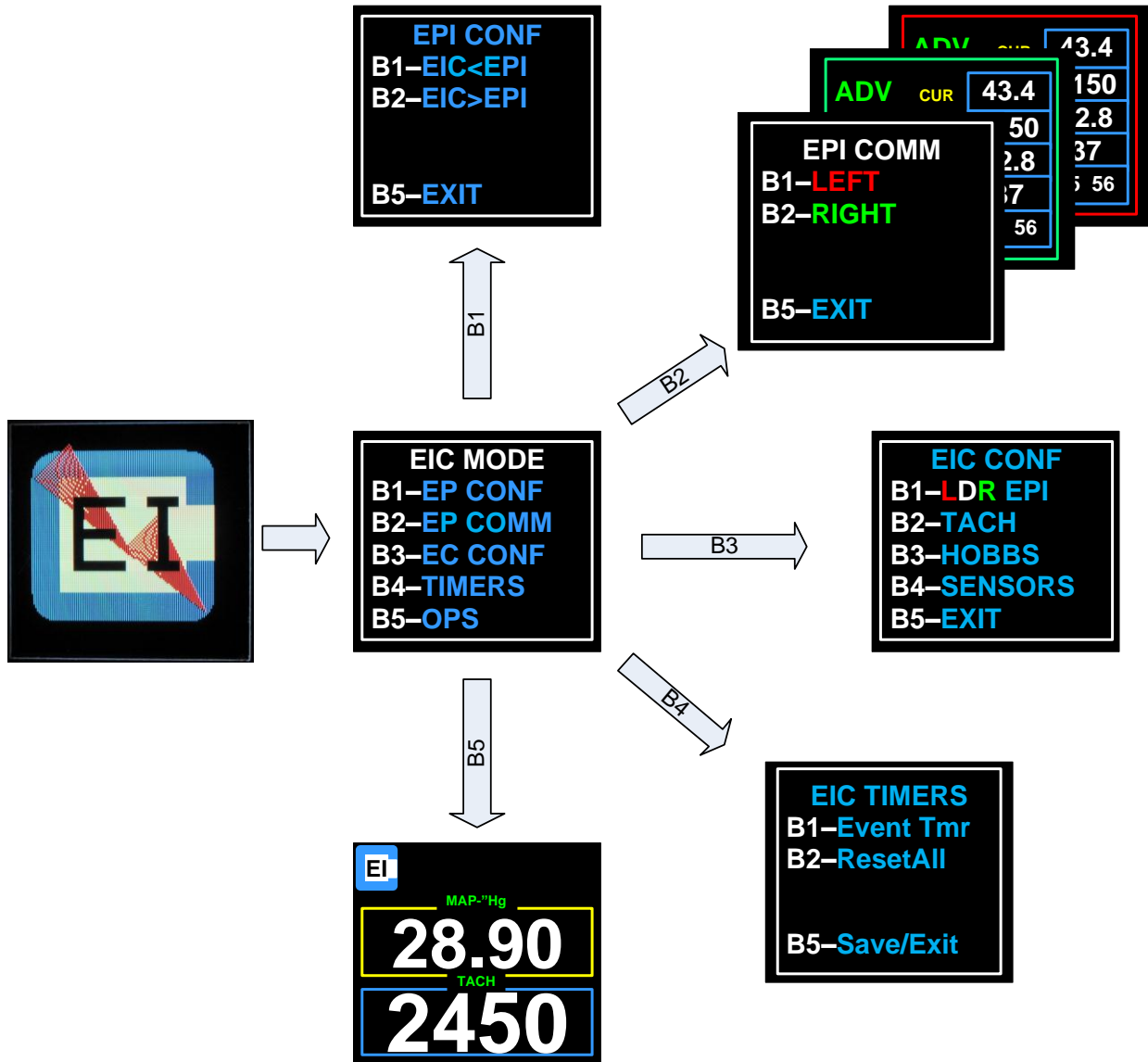

B1-EP CONF

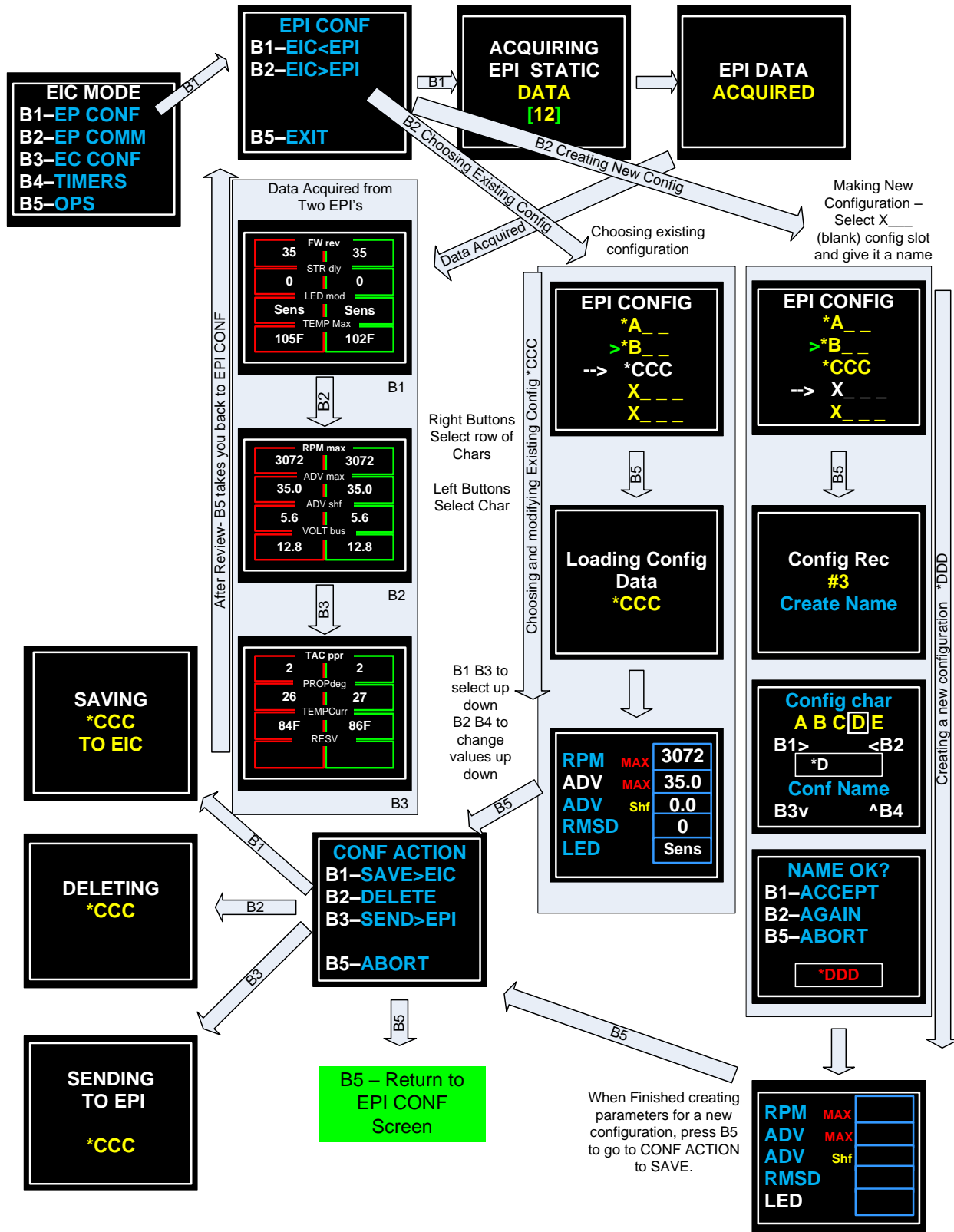

B3-EC CONF

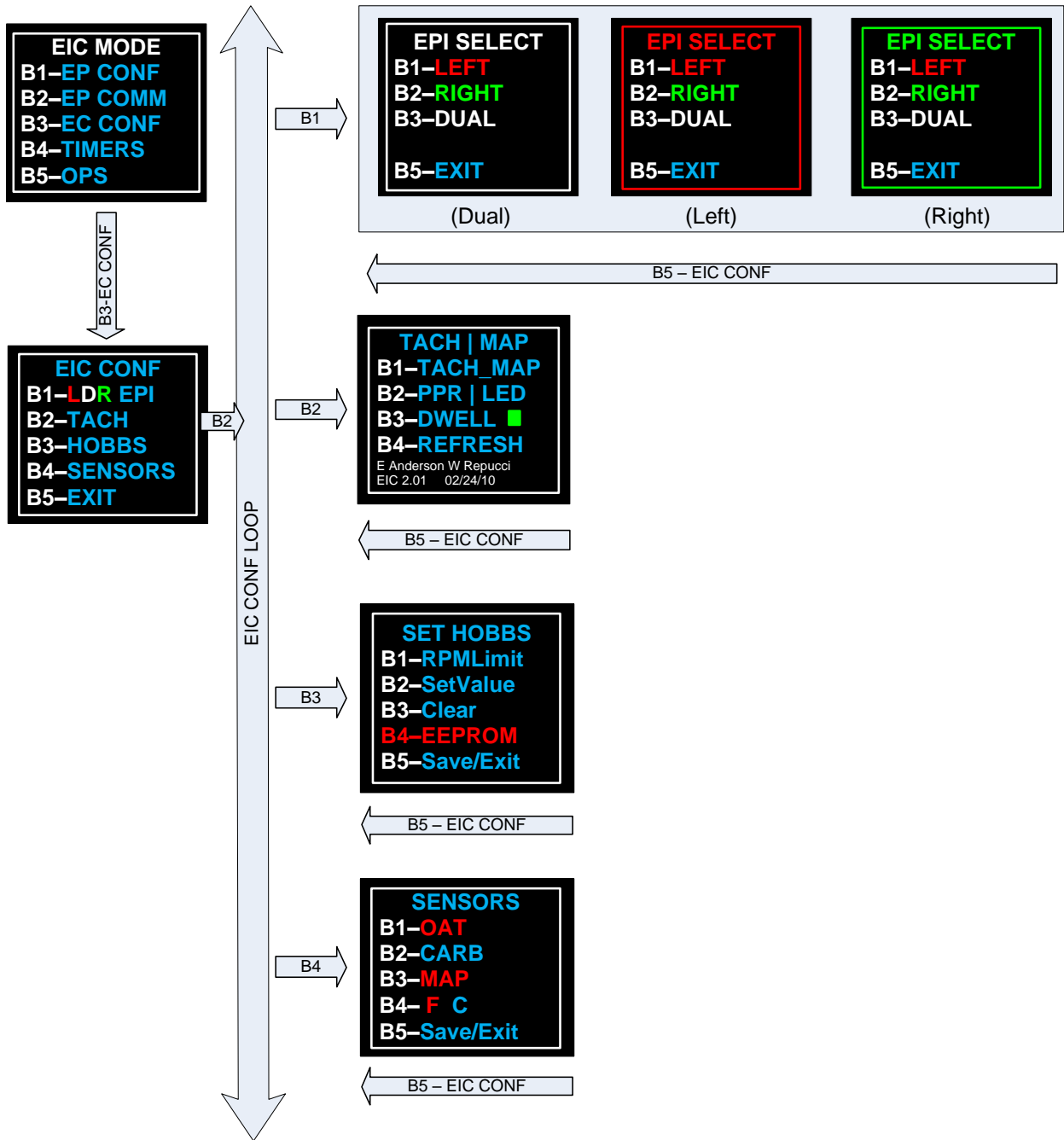

B3-EC CONF → B1-LDR EPI

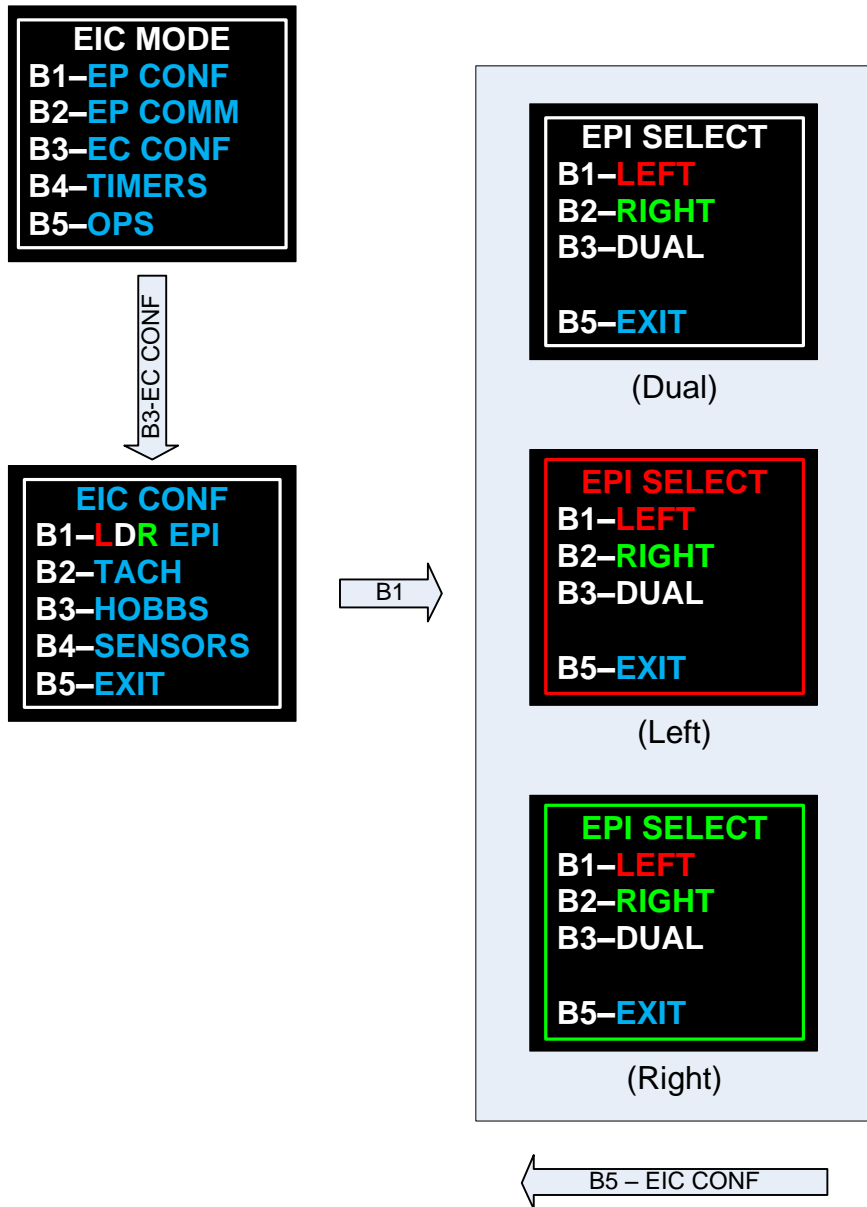

B3-EC CONF → B2-TACH|MAP

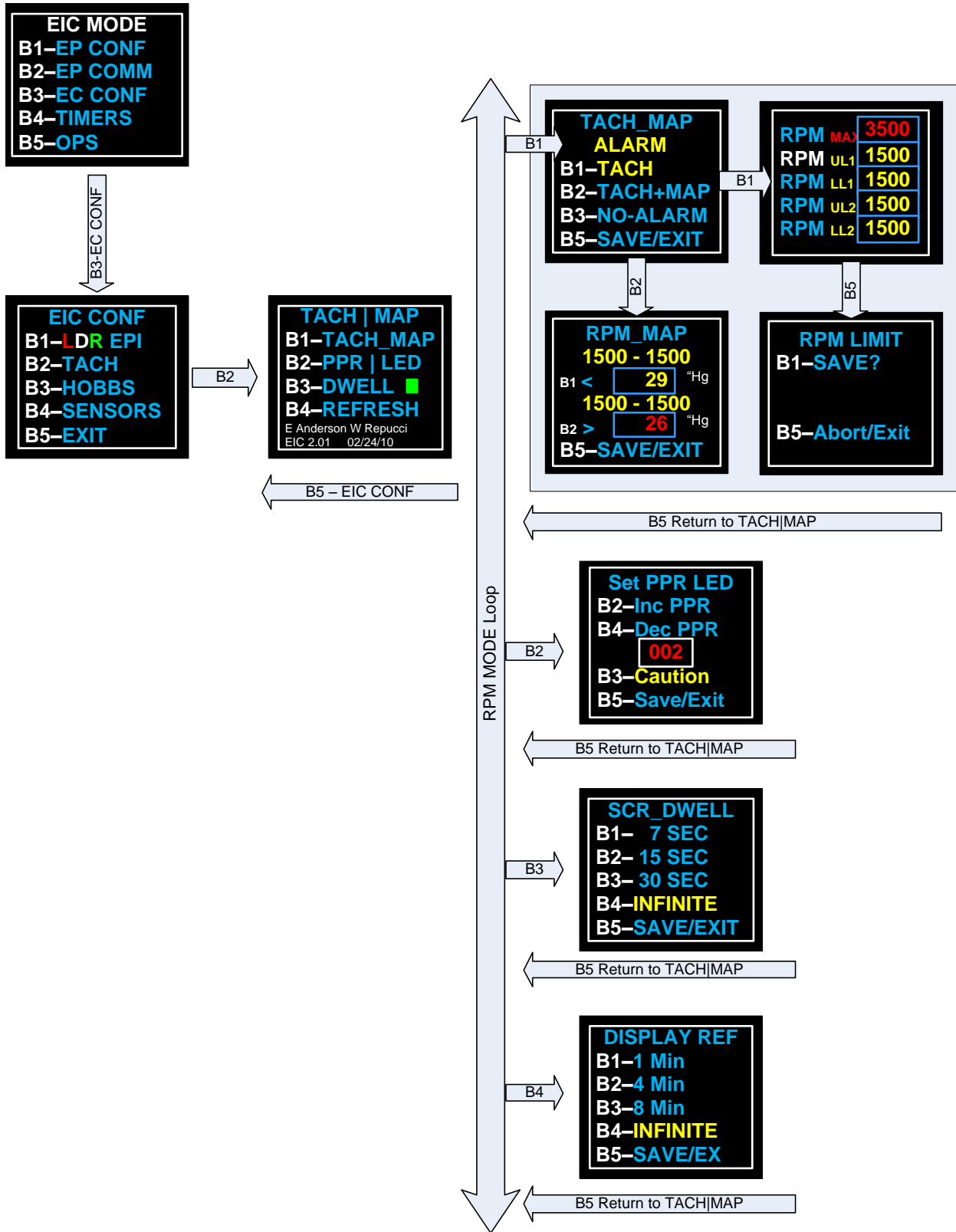

B3-EC CONF → B3 HOBBS

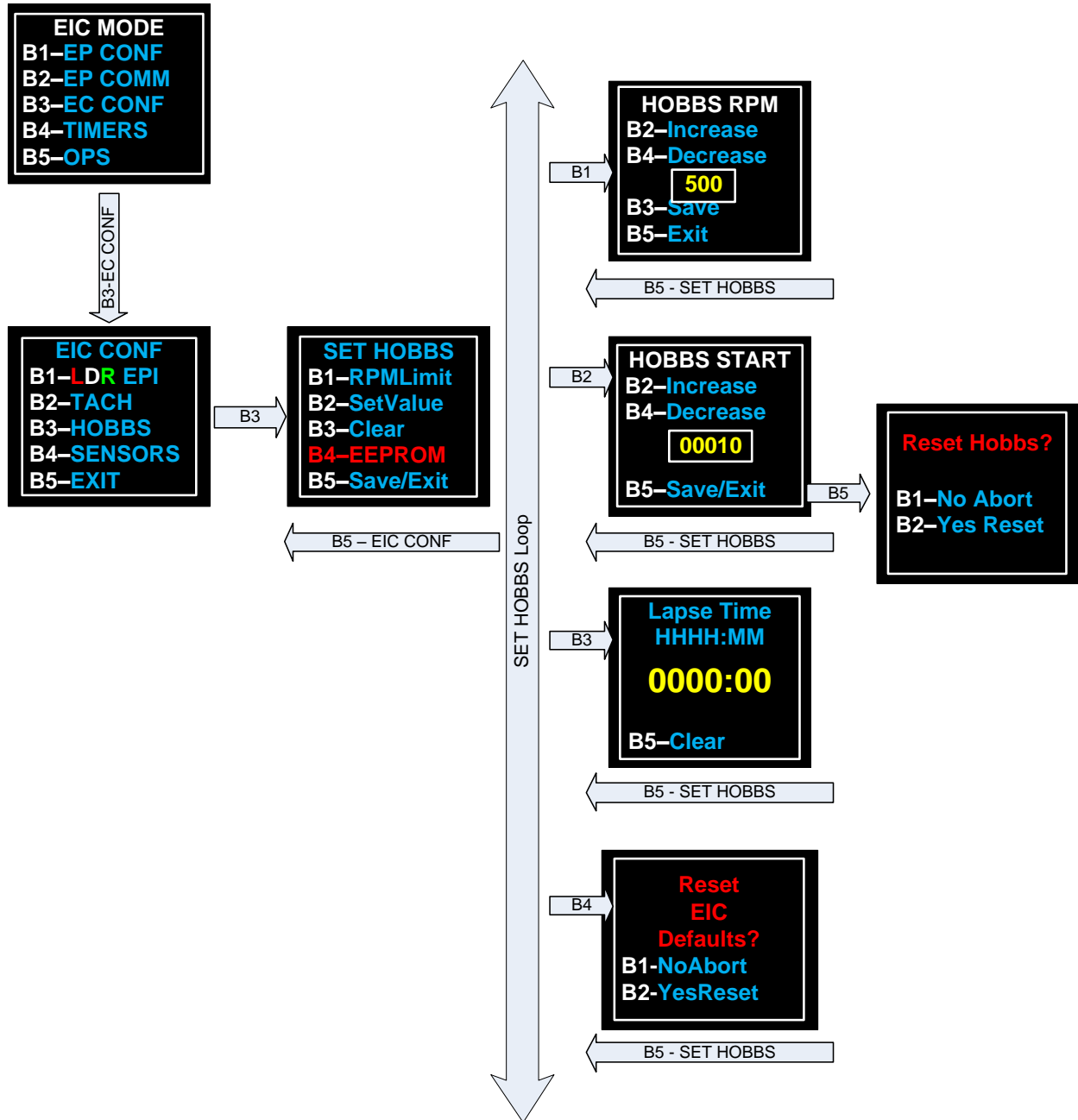

B3-EC CONF → B4-SENSORS

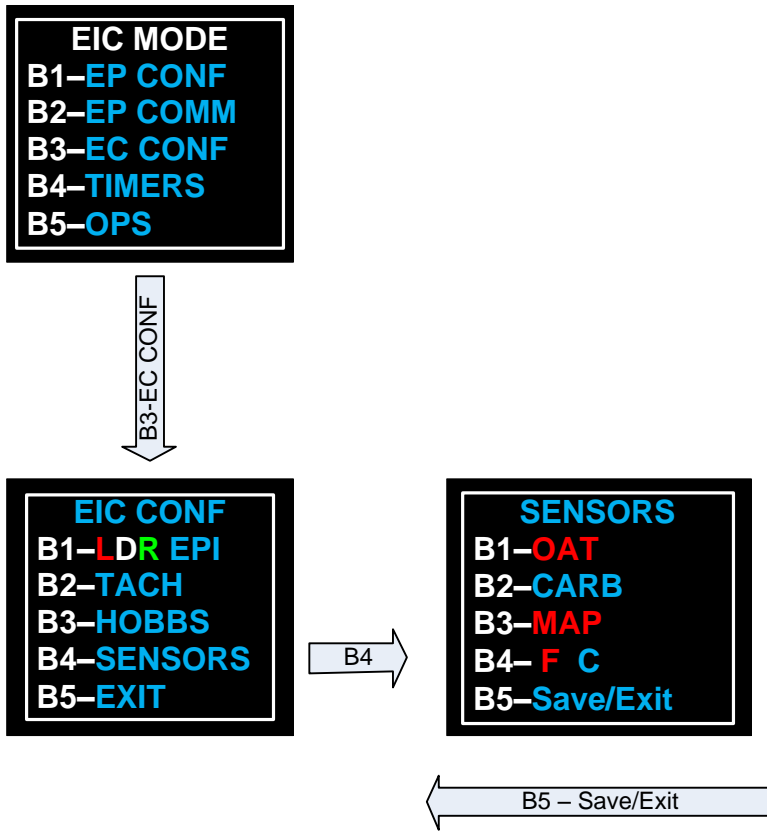

B4-TIMERS

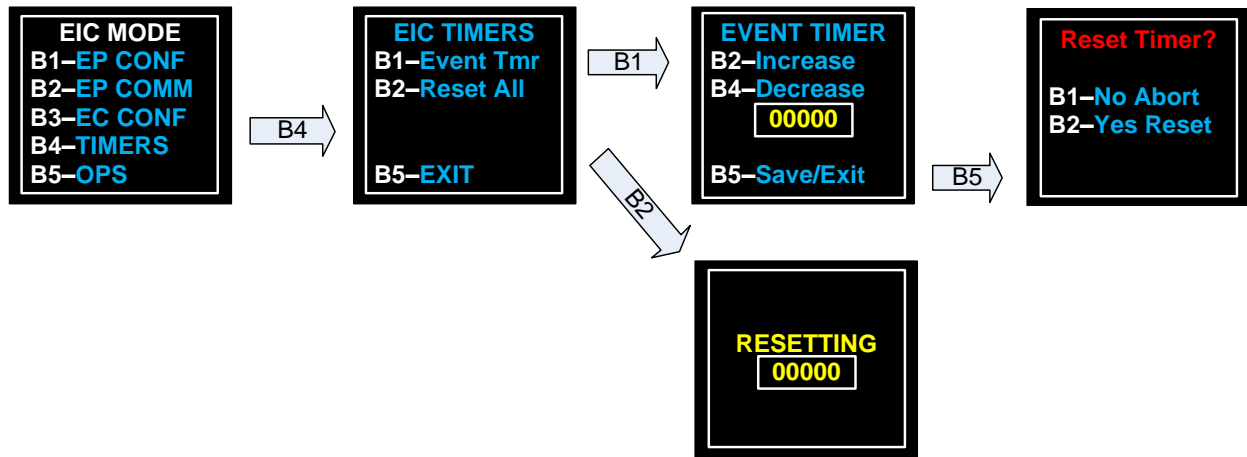

B5-OPS

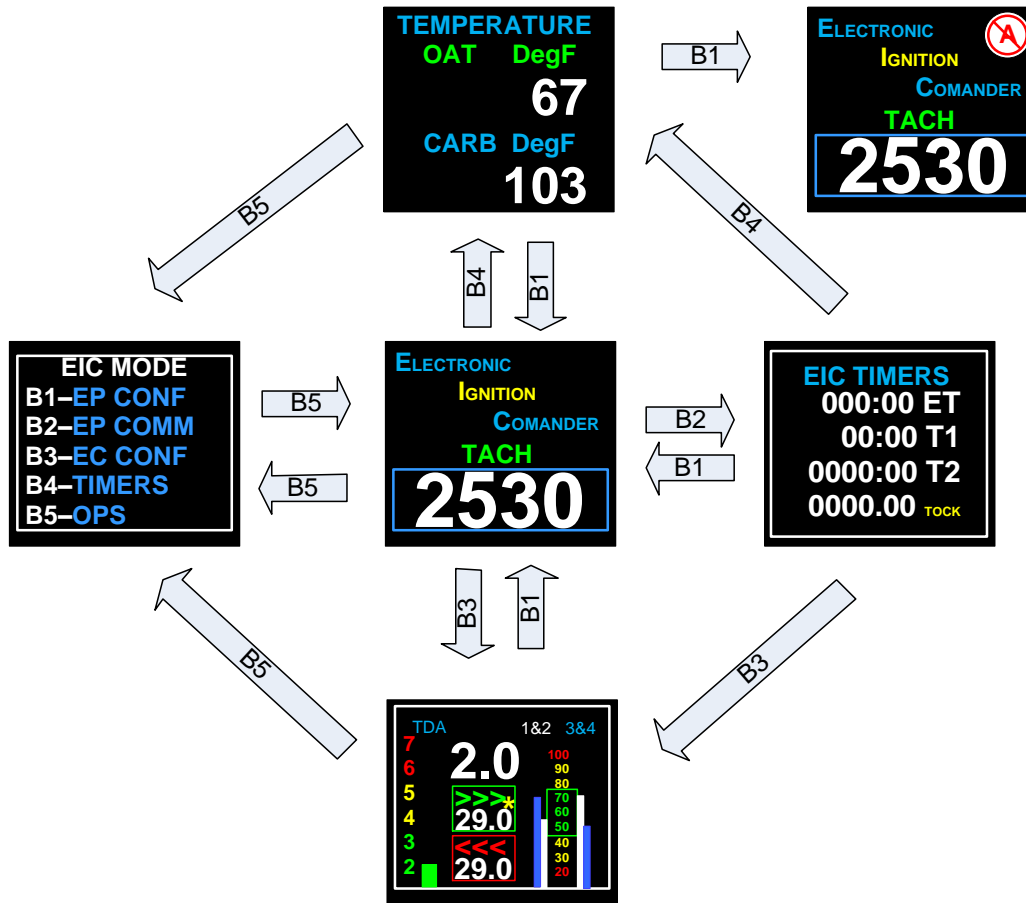

Press B2/B3 – Dimmer and cycle through until the temperature screen is displayed. The Temperature screen will only be displayed if one temperate probe is installed and the EIC is configured.

Screen Maintenance

Protective Cover

The EICommander is shipped with a removable plastic cover on the display. This is to protect the screen during shipment.

After installation, remove the cover for best viewing by grasping the green tab and gently pulling it to the opposite corner of the display. It is best to pull the protective cover off at an angle which parallels the screen as best as possible.

Screen Cleaning

To remove fingerprints, dust, etc from the display use Scotch brand Mending Tape, No 810, or equivalent.

Lightly apply the tape to the screen and gently pull one end in such a way as to produce the smallest angle possible. A few applications may be required.

DO NOT use liquid cleaners on the screen as they may damage the display.

Installation & Configuration

Physical Installation

The EICommander display module is available in two form factors; round, self-contained and rectangular with a remote “brain box”.



The round EIC is designed to fit a standard aviation 2 ¼” (5.715 cm) hole with a four hole screw/bolt pattern. Depth of the instrument is 1 ¾” (4.445 cm). When using a standard plug and “shell”, the total installed depth required is 3” (7.62 cm).

Installed weight is 3 ounces, not counting wire and connector.

Locate a suitable location that does not interfere with any aircraft function such as, but not limited to, control operation, throttle, mixture, propeller, carburetor heat controls and more. It is up to you, as the installer to determine a suitable and safe mounting location for the EICommander.

Make a standard 2 ¼” instrument hole with four bolt holes. Insert the display module through the hole and secure with the provided screws and locknuts.



The rectangular EICommander is 3” (75 cm) wide by 1 9/16” (4 cm) tall and stands “proud” of the panel by 1/4” (.635 cm). This unit requires 1 ½” (9 cm) of clearance for the connector, which will penetrate the instrument panel. Installed weight is similar to the round EIC.



The “brain box” is 3 9/16” (9 cm) long (including mounting tabs) by 2 ½” (4 cm) wide by 1” (2.54 cm) high. The “brain box” is connected to the display unit via a 6” (15 cm) ribbon cable. The “brain box” will require room for the DB15 connector, approximately 2” (5 cm) is adequate.

Wiring

Power to the EICommander should be provided independent of either ignition. This is required so the EICommander unit will continue to function and provide adequate notification(s) should the electronic ignition’s power source fail for any reason.

The following table and diagram indicate the proper wiring configuration for connecting the EICommander to any combination of E or P model ignitions.

The power and communication requirements for the EICommander unit are minimal, thus 22 AWG wire for all connections will be adequate.

The EICommander requires a 12 volt power feed, protected by a 3 amp circuit breaker or fuse, minimum.

Ground to the EICommander is provided through the EPI(s). This was designed to eliminate the potential of detrimental ground loop interference.

The wiring harness must terminate with a two row, 15 Pin "D-Sub", Male connector, with a hood and appropriate hardware to secure the connector to the EICommander.

Wiring configuration

CAUTION

In a dual EPI configuration, both EPI tach signal wires must be connected to the EICommander for the "Timing Divergence Warning" to operate correctly.

EICommander Wiring Schematic

With DB9 connection for software updates.

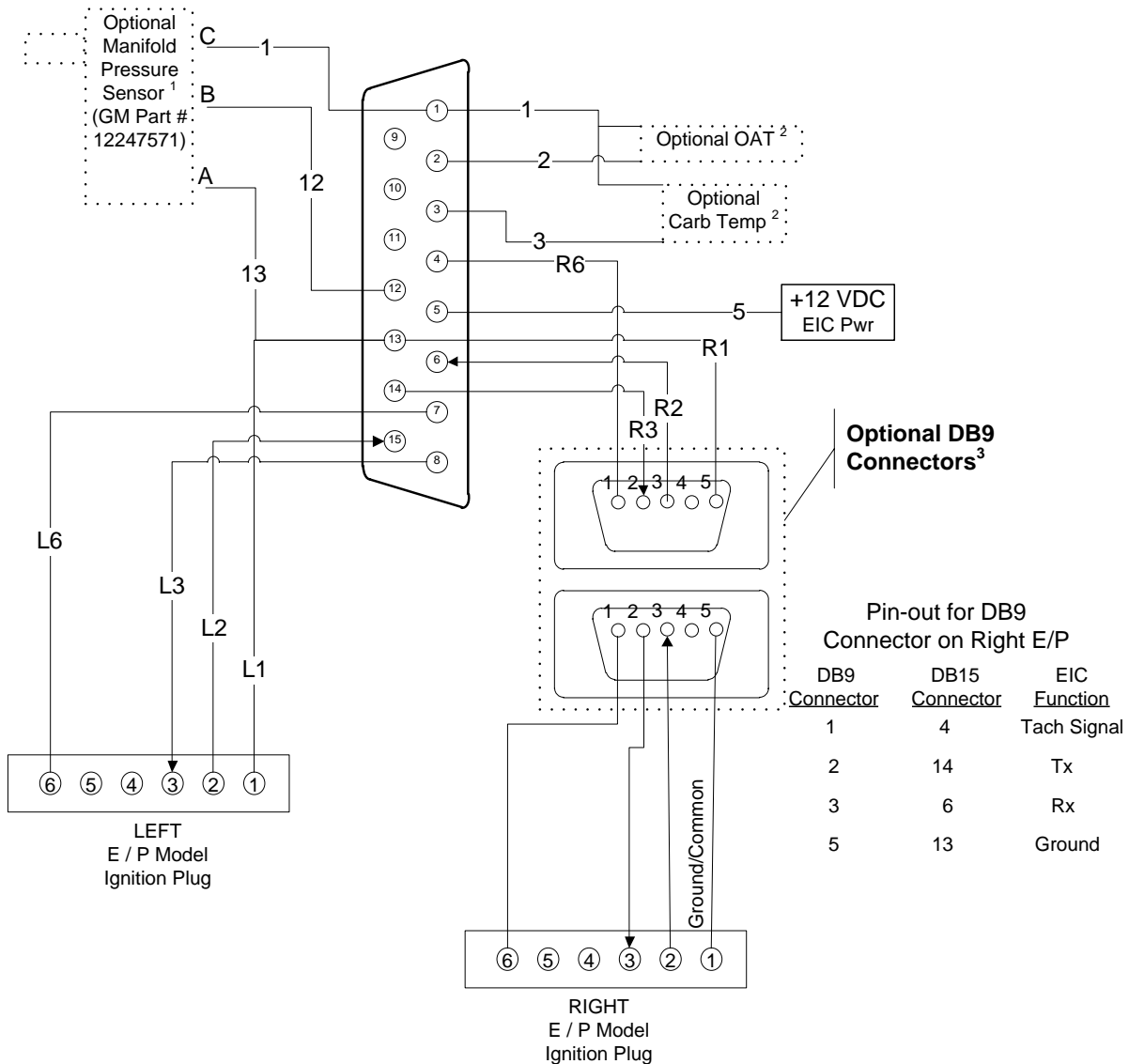

Notes:

1. Connect EIC pin 1 to the MAP sensor pin (Pin C) closest to the hose connector, middle MAP connector (Pin B) to pin 12, remaining MAP connector (Pin A) to EIC ground.
2. Connect temp probe lead(s) to the appropriate pin and the other wire to EIC +5VDC (pin 1). Polarity does not matter.
3. DB9 Connectors are optional based on access to the DB15 plug on the EICommander. Use a female DB9 connector on the EICommander side to facilitate connection to computer dongles for future EIC software upgrades.

✓	DB15 Male Pin#	Function
<input type="checkbox"/>	1	+5 VDC Optional Temp Sensor Power
<input type="checkbox"/>	2	OAT Probe (Optional)
<input type="checkbox"/>	3	Carb Temp Probe (Optional)
<input type="checkbox"/>	5	+12 VDC EIC Power
<input type="checkbox"/>	13	Left EPI "1" Ground
<input type="checkbox"/>	15	Left EPI "2" Control Alternate
<input type="checkbox"/>	8	Left EPI "3" Control Alternate
<input type="checkbox"/>	7	Left EPI "6" is a Courtesy Tach Signal
<input type="checkbox"/>	13	Right EPI "1" Ground
<input type="checkbox"/>	6	Right EPI "2" Control Alternate
<input type="checkbox"/>	14	Right EPI "3" Control Alternate
<input type="checkbox"/>	4	Right EPI "6" is a Courtesy Tach Signal

The male-female DB9 connectors depicted in the right EPI connection are to facilitate future EICommander software upgrades. They may be omitted; however, a separate wiring harness will be required to perform future software upgrades.

EPI Connector Reference:

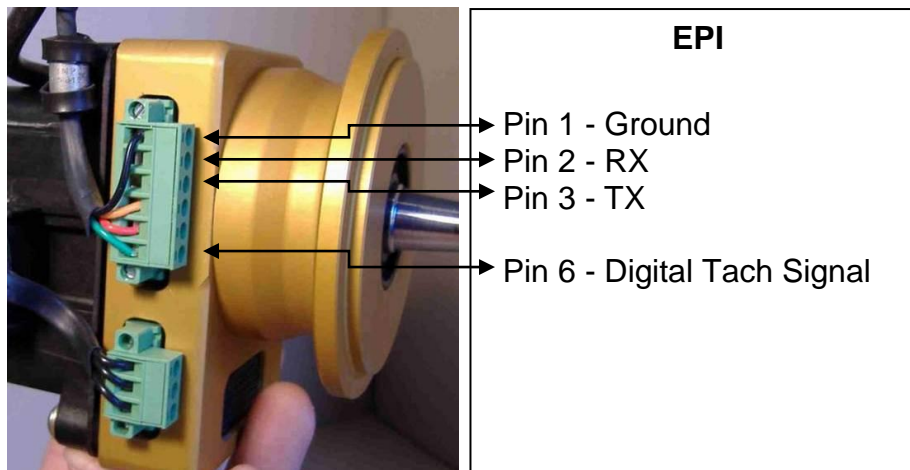

Jumper – Pins 2 & 3

When installing the EICommander, remove the jumper between pins 2 & 3, if installed. The EICommander is designed to manage which timing configurations the EPIs will utilize.

Connecting the EICommander to the Wiring Harness

After the wiring is completed and verified, insert the 15 position Sub D plug into the back of the EICommander and secure with the supplied screws.

Communication Configuration of the EI Commander

It is important to correctly configure the EICommander prior to use. The EICommander must be configured for dual or single EPIs and if single, the location (left or right) of the installed EPI.

To configure the EICommander, follow the steps listed below:

1. Engine shut down and secured. (Use caution to make sure the propeller is not turned during while configuring the EICommander, the ignition will be “hot”.)
2. Apply power to the EPI(s).
3. Apply power to the EICommander (The EICommander Logo Screen will be displayed.)
4. Press any button to bring up the **EIC MODE** screen. (B1 through B5, B6 is the reset button and will display the logo screen.)
5. Press button **B3-EC CONF** to display the EICommander configuration (**EIC CONF**) screen. This screen is used to configure the EICommander, not the electronic ignition.
6. Press button **B1- LDR EPI**, to select Left, Dual, or Right EPI(s).
7. Select the location of the EPI or both, if two units are installed. Color coding is used throughout the EICommander screens to signify which EIC is active. **RED** for the left EPI, **GREEN** for the right, and **WHITE**, if two units are installed:

- a. **B1-LEFT**
- b. **B2-RIGHT**
- c. **B3-DUAL**

The EICommander will signify which channel (left, right, or both) it is communicating with by displaying a **RED**, **GREEN**, or **WHITE** box around the periphery of the active screen. In addition, the color of the title will change to match the screen outline.

8. Press button **B5-EXIT** to save and exit the current screen.

Notes: 1. In a dual EPI setup, there may be times when communications with a single EPI is desired. Return to this screen and select either **B1-LEFT** or **B2-RIGHT** any time. When configured for single EPI operation, data will be displayed on only one side of the screens designed to display data from two EPIs. The appropriate side will display data from the selected EPI and the other side will remain blank, indicating no data (no communication) with the second EPI. When operating in single EPI mode, the TDA warning is not enabled.

2. When the EICommander has been configured for dual EPIs, there are several places within the operational menus where the selection of left or right EPIs is required. For example, if the engine is running, you are permitted to make on-the-fly changes to the parameters of only one EPI at a time for safety reasons. Therefore the program will ask you to select either the left or right EPI. After adjusting one EPI, the other may be selected and modified or the active configuration may be saved and pushed to both EPIs simultaneously.

Tachometer Configuration

The digital tachometer function includes one redline and two yellow ranges.

The red LED mounted on the bottom of the EICommander will flash whenever operation exceeds the RPM limit defined.

The red LED may be optionally configured to light whenever operating in a yellow range. This feature is designed for those pilots whose flying habits do not allow them time to focus on the RPM gauge, such as people who participate in formation flying.

Review the operating handbook for the engine and propeller combination that will be managed by the EICommander to determine what operating limitations may apply.

The redline and yellow range parameters are set on the **RPM MODE** screen. To navigate to this screen press **B3-EC CONF**, **B2-TACH**, and **B1-TACH_MAP**.

Setting the Tachometer Redline and Yellow Ranges

Set the limitations by pressing button **B1-TACH**. Using buttons **B1** (up), **B3** (down), **B2** (increase), and **B4** (decrease), set the redline and yellow RPM caution limits and ranges.

Save the new tachometer limits by pressing **B5-Save/Exit**. Press **B1-Save?** to save the configuration or **B5-Abort/Ex** to discard the changes and return to the **TACH|MAP** screen.

Optional Yellow Caution Alarm

From the **TACH|MAP** screen, press **B2-PPR |LED** to navigate to the **Set PPR LED** screen. Toggle the yellow range LED on and off by pressing **B3-Caution**. The word “**Caution**” will change color; yellow indicates the LED is off, red indicates the LED will flash when operating within a yellow range.

Save the new setting by pressing **B5-Save/Exit**.

Manifold Pressure Alarm Configuration

If the optional Manifold Pressure (MAP) sensor is installed the EICommander may be configured to trigger an alarm.

The MAP alarm parameters are set on the **RPM MODE** screen. To navigate to this screen press **B3-EC CONF**, **B2-TACH**, and **B1-TACH_MAP**.

Setting the MAP Ranges

Set the tachometer caution ranges as described above prior to setting the MAP limits.

Note: The MAP function must be activated prior to setting the MAP ranges. If this function is not active, the button will be “greyed” out.

Set the MAP limitations by pressing button **B2-TACH+MAP**. Button **B1** toggles the greater than (>) less than (<) symbol for the RPM range displayed at the top of the screen. Button **B3** toggles the greater than (>) less than (<) symbol for the RPM range displayed at the bottom of the screen.

Buttons **B2** and **B4** selects/deselects which MAP box on the screen is active. Once a MAP box is selected (numbers within the active box turn red), buttons **B2** and **B4** are used to increase and decrease the manifold pressure, in inches of mercury (”Hg). **B2** selects/modifies the upper box and **B4** selects/modifies bottom box MAP value.

To switch between the upper and lower TACH+MAP entry box, press either **B1** or **B3** exit the entry function. Then use **B2** or **B4** to select the desired MAP box.

Buttons **B1** and **B3** are also used to toggle between the conditional signs “<” and “>” for triggering the MAP alarms.

Press button **B5** to save changes and exit.

Hobbs Meter Configuration

The Hobbs meter parameters are set on the **SET HOBBS** screen. To navigate to this screen press **B3-EC CONF**, followed by **B3-HOBBS**.

Setting Hobbs Recording Threshold

The RPM at which the Hobbs meter begins recording flight time may be set by pressing button **B1-RPMLimit**.

Increase the displayed threshold by pressing **B2-Increase** and reduce it by pressing **B4-Decrease**. Holding either button down will increase (accelerate) the rate at which the numbers change. Releasing the button will allow the user to increment / decrement the number in smaller units.

Save the new threshold by pressing **B3-Save** and exit the screen by pressing **B5-Exit**.

Setting Hobbs Meter

The starting Hobbs meter time is set on the **HOBBS START** screen. Press **B2-SetValue**. Increase the displayed Hobbs time by pressing **B2-Increase** and reduce it by pressing **B4-Decrease**. Holding either button down will increase (accelerate) the rate at which the numbers change.

Save the new Hobbs time by pressing **B5-Save/Exit**.

Pulses per Revolution (PPR)

The Pulses per Revolution (PPR) must be set for the tachometer to function properly. The allowed values are 0, 1, 2, 4, 6, 7, and 8. (Setting the PPR to zero (0) provides a PPR of ½ for those with the Westech sine wave ½:1 ratio Tach signal generators.)

The PPR is set on the **SET PPR LED** screen. To navigate to this screen press **B3-EC CONF**, followed by **B2-TACH**.

From the **TACH|MAP** screen, press **B2-PPR|LED** to navigate to the **Set PPR LED** screen. Increase or decrease the PPR by pressing **B1-Inc PPR** or **B4-Dec PPR** while observing the value in the white box.

Save the new setting by pressing **B5-Save/Exit**.

Dwell

Set the length of time to display a screen before returning to the Tach screen.

The Dwell alarm parameters are set on the **SCR_DWELL** screen. To navigate to this screen press **B3-EC CONF**, **B2-TACH**, and **B3-DWELL**.

Select the desired dwell time, **B1** for seven seconds, **B2** for 15 seconds, **B3** for 30 seconds, and **B4** for infinite dwell. The selected dwell limit will change color to yellow.

Press **B5** to save and exit the selected dwell limit.

Refresh

Set the length of time between screen repaints.

Due to the technology used in the EICommander's organic LED display, the screen may need to be refreshed occasionally. The refresh rate may be set in increments of one, four, eight minutes, or never (infinite). When the screen is refreshed, a flicker may be observed. If **B4-IFINITE** is selected, the screen may be refreshed manually by pressing any button to select another display, then returning to the current screen. If in the TACH loop, press any button to refresh the current screen.

Options

The EICommander has the optional ability to display Manifold Pressure (MAP), Carburetor Temperature, and Outside Air Temperature (OAT) when the appropriate sensors are installed and configured.

Note: If the sensors are not installed and configured, the MAP, OAT, and Carburetor temperature screen will not be displayed.

The temperature sensors are not included with the EICommander but can be purchased directly from:

Dynon Avionics Inc.
19825 141st PL NE
Woodinville, WA 98072

Outside Air Temperature Sensor

Part #: 100433-000

Description: OAT Probe, connects only directly to EMS/FlightDEK

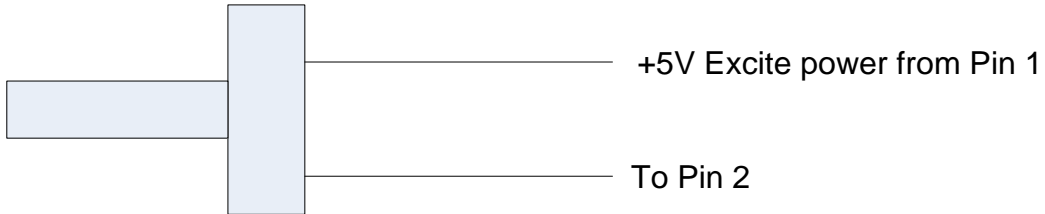

Polarity does not matter

Carburetor Temperature Sensor

Part #: 100468-000

Description: Carb Air Temperature, ¼-28 UNF, -50° to 150°F

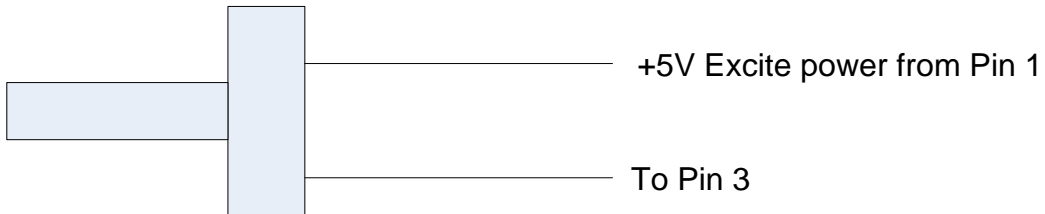

Polarity does not matter

Manifold Pressure

The manifold pressure sensor is not included with the EICommander but can be purchased from your local auto parts retailer, request Delphi / GM 2 Bar Map Sensor, part number 12247571. Or purchase the item from Dynon Avionics. (It may be possible to connect to an existing MAP sensor, if it is comparable to the above listed item.)

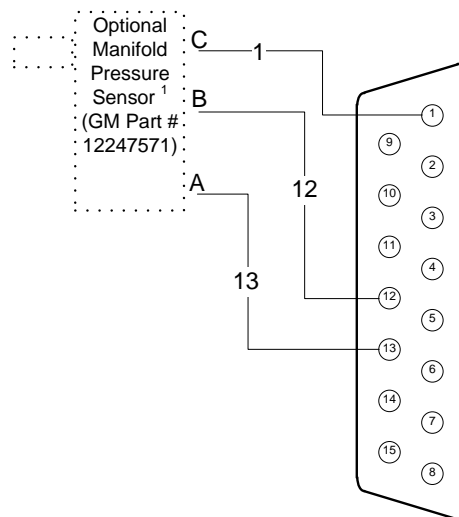

Option Configuration

Outside Air Temperature: From the **B3-EC CONF** screen, press the **B4-SENSORS** to display the SENSORS screen.

Select the desired option by pressing the appropriate button. Active features will be displayed in red.

Selecting **B4-F C** will toggle the temperature display between Fahrenheit and Celsius. Press **B5-SAVE/EXIT** to exit the screen and save the settings.

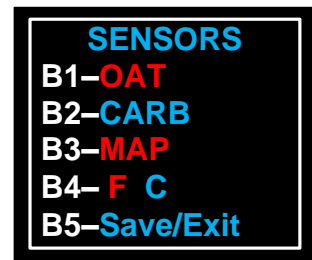

Software Updates

Updating the EICommander software is a quick and easy process. However, caution must be exercised when performing the updates so as not to negatively impact the EICommander or the EPIs.

CAUTION

When updating the EICommander the EPIs should remain powered off to eliminate the possibility of corruption during the software update process.

When updating the EICommander, the engine should not be running.

Bootloader Wiring Harness

If the EPIs are not installed as described above, a special wiring harness is required for performing the updates. The following diagram depicts the proper harness configuration.

Power can be provided by the ship's 14 volt electrical bus or via a common 9 volt battery.

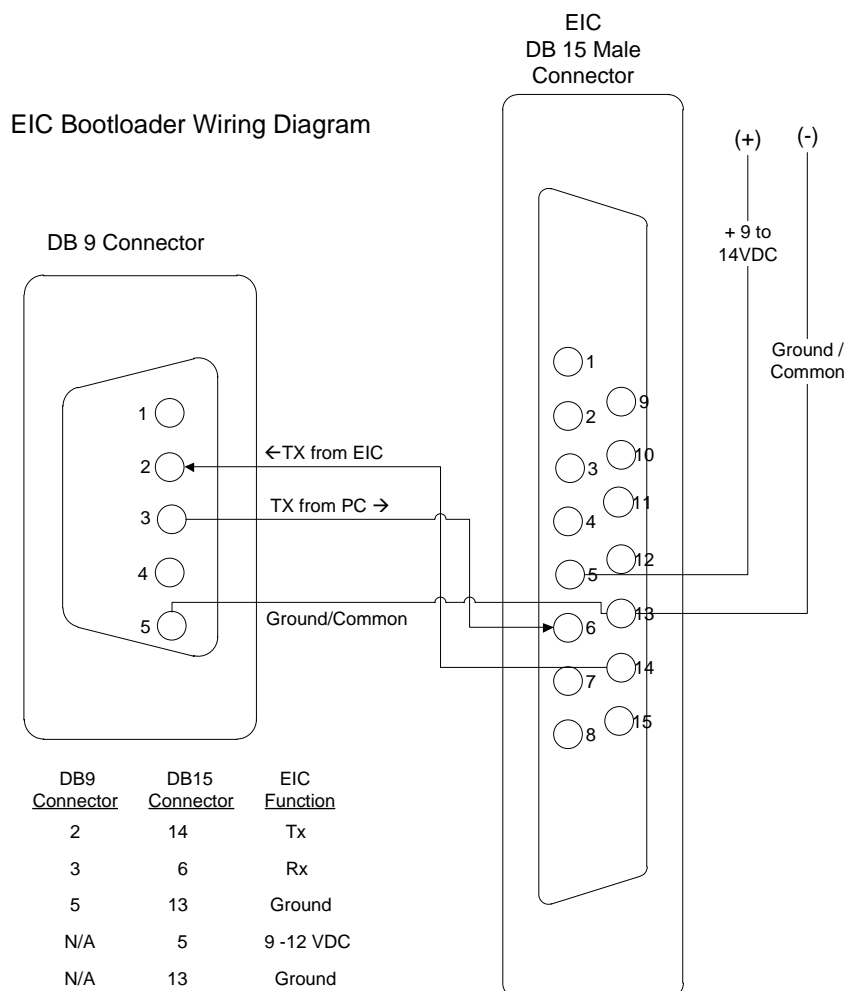

Software Downloads

Contact EICommander at info@eicommander.com for a copy of the Bootloader program. No installation is required, just store the program file in an easy to remember location.

Retrieve current version of the EICommander software from the WWW.EICOMMANDER.COM/DOWNLOADS web site. This file should be stored in an easy to remember location.

Performing Software Updates

The steps listed below must be followed exactly. Updating the EICommander will not overwrite existing settings or retained values such as the current Hobbs number.

- | ✓ | Step | Description | Notes |
|--------------------------|------|---|-------|
| <input type="checkbox"/> | 1 | Download the current EICommander from WWW.EICOMMANDER.COM/SUPPORT | |
| <input type="checkbox"/> | 2 | Connect the Bootloader wiring harness to the EICommander and to the host PC. | |
| <input type="checkbox"/> | 3 | Apply power to the EICommander.
Warning: Do not apply power to either EPI.
Start the mikroBootloader program. | |



- 4 Click on **P18**.

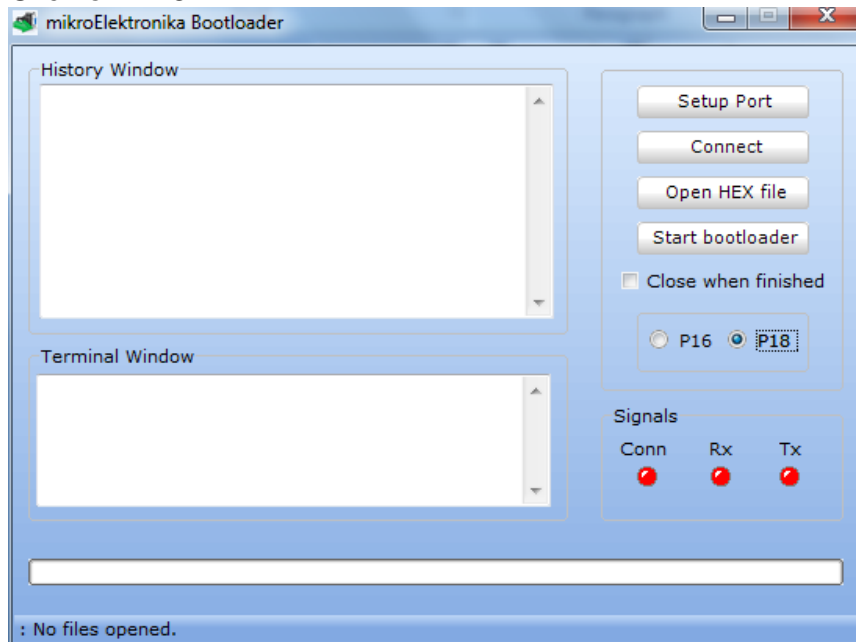

- 5 Click on the “**Setup Port**” button and select the appropriate comm port and change the “**Baud rate**” to

“115200”.

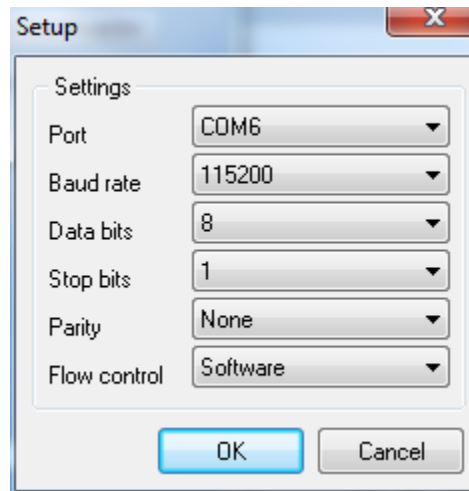

- 6 Click on “**Open HEX file**” and select the software update.
- 7 Press the reset button **B6** on the EICommander and within two seconds click on the “**Connect**” button.
- 8 Click the “**Start bootloader**” to perform the software update.
The software update should take between 30 and 90 seconds to complete.
- 9 Upon software update completion, click on “**Downloading program has finished Reset PIC. OK**”.

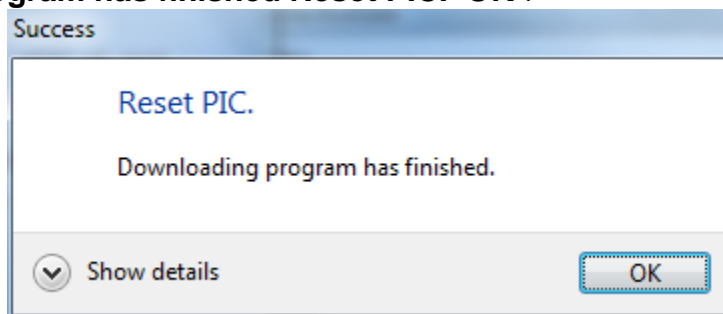

- 10 Close the microBootloader program.
- 11 Disconnect the Bootloader wiring harness and reconnect the EICommander to the aircraft’s wiring and secure it.
- 12 Verify the EICommander is operating correctly by powering up the EPI(s), the EICommander, and retrieve the static data from the EPI(s).

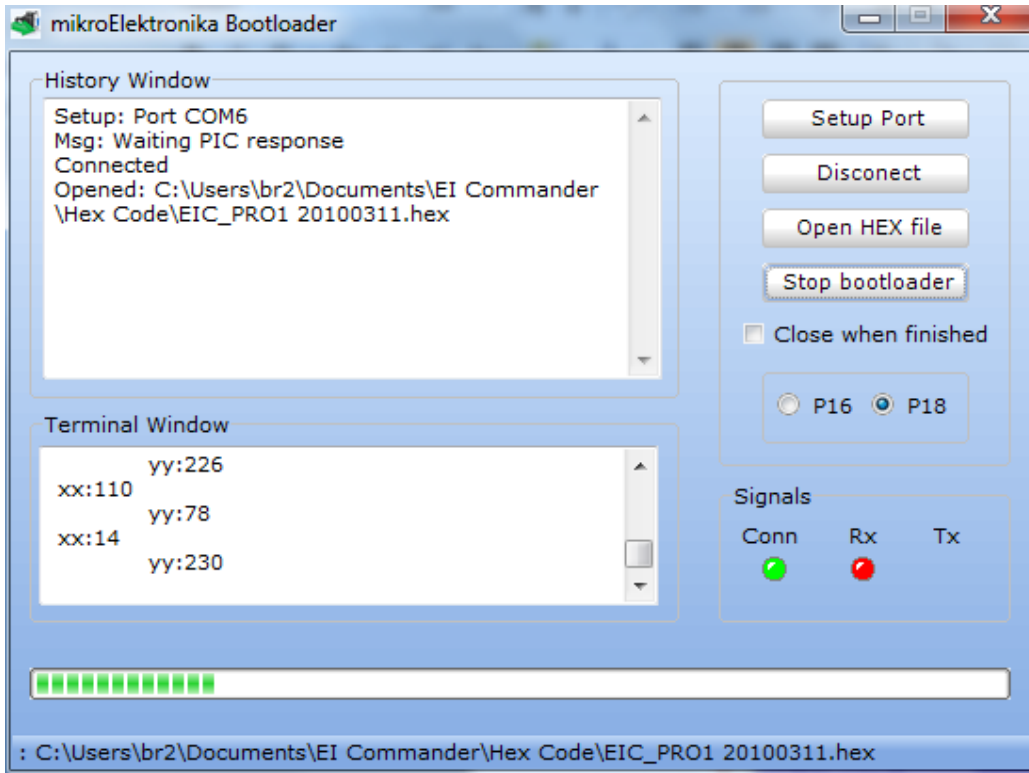

Trouble Shooting

NO COMM WITH EIP	Verify the EPI is wired correctly and has power.
In Dual mode but only displaying data from one EPI	Verify dual mode configuration. Verify the EPI is powered up. Verify wiring. No error message is displayed if one EPI is powered down.
No Communication with EPI	Verify wiring. Verify configuration (left, right, dual)
Lost communication with one EPI	Verify the EPI is powered up. Verify the EPI is not grounded. Display the dual static screen, see B1-EP CONF to reset the EPI.
TDA Alarm	Possible Causes: <ol style="list-style-type: none">1. Changing the timing of one EPI by more than six (6) degrees by using the “On The Fly” change screen. (Probably most frequent cause.)2. Different timing configurations sent to the EPIs.3. One EPI manifold pressure tube is leaking or not connected - causing divergence due to different manifold pressure received by the two EPIs.4. One TACH signal lost for any reason (broken wire or loose wire, etc.).5. EPI’s Top Dead Center (TDC) not set to the same prop angle.<p>If both EPI’s TDC do not match the engine, the most likely cause is they were never set or set incorrectly. If one EPI is set to TDC and the other is not, it is possible only one was set correctly using the “blow in the tube” method due to the routing of the manifold pressure lines. However, it is possible that one EPI is defective.</p>6. Possible wear condition in one EPI magneto gear. Remove EPI and inspect gear for wear. Replace with a PMA’ed gear and reinstall ignition according to the manufacture’s recommendations.7. One EPI has a malfunction and has lost its timing mark

Glossary / Definitions

*	EIComander status indicator.
ADV	The current degrees of advance, as reported by the EPI(s).
ADV CUR	The current degrees of advance, as reported by the EPI(s).
ADV MAX	The maximum allowable timing advance. See the E-mag Ignition manual for details.
ADV Shf	The maximum degrees of shift, up or down, assigned to the timing advance curve, as reported by the EPI(s).
C1/2-C3/4	Coil pack status as reported by the EPI(s). C1/2 – Coil pack for cylinders 1 and 2. C3/4 – Coil pack for cylinders 3 and 4.
CARB DegF / CARB DegC	The temperature as reported by the carburetor temperature probe in either degrees Fahrenheit or Celsius.
COMPARISON	Identifier for the new vs. old or prior configuration.
EC CONF	Configure the EICommander.
EICAD	A program provided by E-MAG Ignitions for monitoring and tuning E and P model electronic ignitions.
EIC<EPI	Retrieve information from the EPI(s) to the EICommander.
EIC>EPI	Send information from the EICommander to the selected EPI(s).
E-MAG Ignitions	The manufacture of E and P model electronic ignitions. See http://www.emagair.com/Index.htm
EP COMM	Communicate with the EPI(s). Retrieve and send information to select EPI(s).
EP CONF	Configure the EPI(s).
EPI	Reference to either E or P model electronic E-MAG Ignitions.

FW REV	Firmware revision, as reported by the EPI(s).
LED MOD	LED Mode, as reported by the EPI(s).
LL1	Lower Limit 1. Used to define the bottom of the first yellow RPM range.
LL2	Lower Limit 2. Used to define the bottom of the second yellow RPM range.
OAT	Outside Air Temperature.
PPR	Pulses per Revolutions. Used by various tachometers to count the number of times the engine's crankshaft rotates in one minute.
PROP DEG	Current position of the propeller relative to TDC, as reported by the EPI(s).
RMSD	Run Mode Start Delay. Instructs the ignition to fire the sparkplugs after "X" number of crankshaft revolutions.
RPM	Revolutions per Minute. Used to measure engine speed.
RPM MAX	Maximum allowable RPM, as reported by the EPI(s). Also known as the "rev limiter".
RPM CUR	The current RPM, as reported by the EPI(s).
STR DLY	Run Start Delay, as reported by the EPI(s).
TAC PPR	Tachometer Pulses Per Revolution, as reported by the EPI(s).
TDC	Top Dead Center. The position of an internal combustion's cranks shaft when cylinder #1 is at the top its compression stroke.
Temp	Current internal temperature, as reported by the EPI(s)
TEMP CUR	The current temperature of the EPI(s), as reported by the EPI(s).
TEMP MAX	Maximum temperature recorded, as reported by the EPI(s).
UL1	Upper Limit 1. Used to define the top of the first yellow RPM range.

UL2	Upper Limit 2. Used to define the top of the second yellow RPM range.
V	Volts
Volt	Current voltage, as reported by the EPI(s).
Volt bus	Current voltage, as reported by the EPI(s).

Screen Definitions



Logo screen: EICOMMANDER logo. Displayed upon power up or reset.

Page: 20

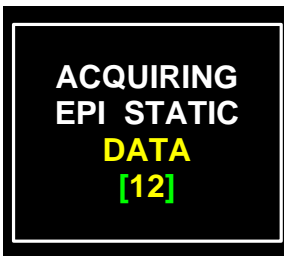

Informational screen: The EICOMMANDER is busy retrieving data from the EPI(s). The countdown window, [12], indicates progress.

Page: 21

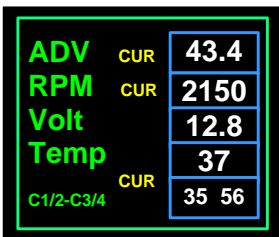

Active stream mode screen: Displays the current ignition advance, RPM, voltage, ignition temperature, and ignition harness status.

Page: 22

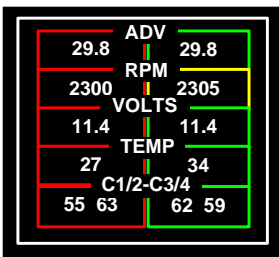

Dual View screen of the Operating configuration values – such as limits or operating values: Displaying the current total advance, RPM, internal voltage, internal EPI temperature, and the status of the ignition harness.

Page: 22

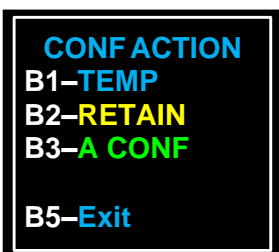

Confirm Action menu: Used to tell the EICOMMANDER how to process the recently made EPI changes.

B1-TEMP Temporary change, do not retain the current setting in the EICOMMANDER or EPI's memory.

B2-RETAIN Save the current setting to the EPI's memory

B3-A CONF Send the factory default "A" configuration to the EPIs immediately.

B5-Exit Exit the current screen.

Page: 22

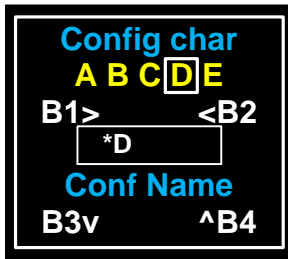

Configuration Naming screen: Buttons B1 and B2 will select the desired character by moving the highlight box right and left. Buttons B3 and B4 will scroll to the next group of five alpha/numeric characters. Press button B5 to select the highlighted character. Maximum configuration name length is 3 characters.

Page: 21



Informational screen: The EICCommander is creating a new timing configuration. In the example displayed, the third memory location has been selected and before the mandatory configuration naming screen is displayed.

Page: 21



Informational screen: The EICCommander is in the process of removing a timing configuration from its internal memory. Note: Configurations *A and *B may not be erased.

Page: 21



Display Refresh screen: Select the time interval between screen refreshes.

Page: 25

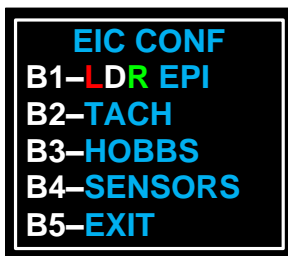

EIC CONFigure screen: Main EICCommander configuration screen.

Page: 23

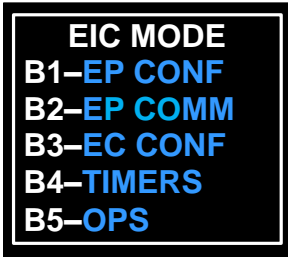

Main Menu.

Page: 20

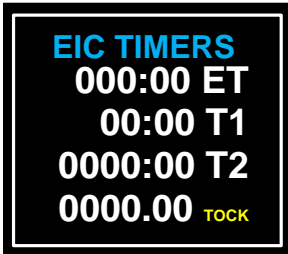

Timer screen

Page: 29



Timer menu.

Page: 28



Tachometer screen.

Page: 29

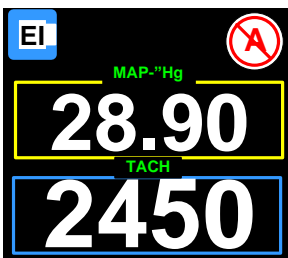

Tachometer screen with a symbol in the upper right hand corner indicating the TDA function has been disabled.

Page: 29



EPI selection screen. When the EICommander is configured for Dual EPIs, this screen will appear and user must select the Left or Right EPI. If only one EPI is installed and/or the EICommander is configured for Left **OR** Right, this screen will not be displayed when button **B2-EP Comm** is selected on the prior screen and the EICommander will automatically retrieve data from the configured EPI.

Page: 22

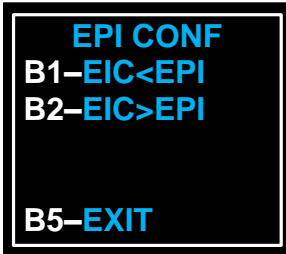

B1-EP CONF: EPI configuration screen.

Page: 21



Informational screen: The EICommander has completed retrieving data from the EPI(s) and is formatting the data for display.

Page: 21

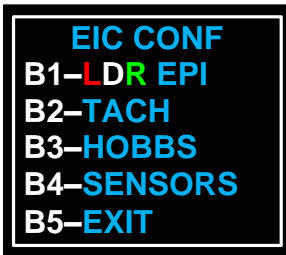

EICommander configuration main menu.

Page: 23



Select EPI Communication configuration menu.

Page: 23

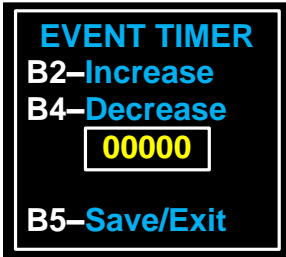

Event timer setup screen.

Page: 28

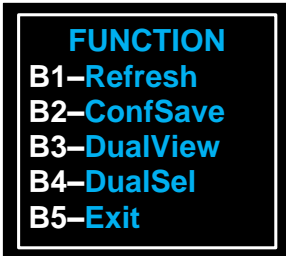

Function menu: This screen indicates the various functions available while communicating with the EPI in Comm mode.

Page: 22

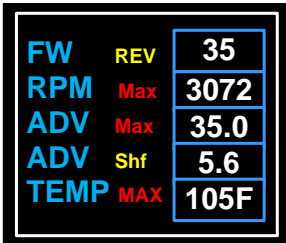

Static information display screen. Firmware version, maximum RPM AKA rev limiter, maxing timing advance, timing curve shift value, and maximum temperature, in Fahrenheit, recorded by the EPI.

Page: 22

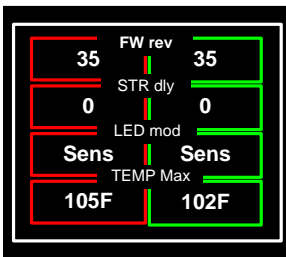

Data retrieval and display screen 1. Displays the configurable elements retrieved from two EPIs.

Firmware revision number, run mode start delay, LED mode, and the maximum temperature recorded by the EPIs,

Note: If this screen is selected and only one side is populated with data, check the connection to the EPI whose data is missing.

Page: 21

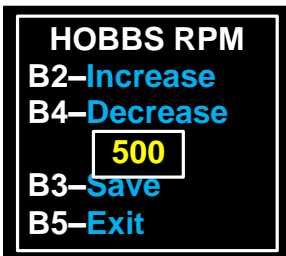

Start Hobbs recording RPM setup screen.

Page: 23

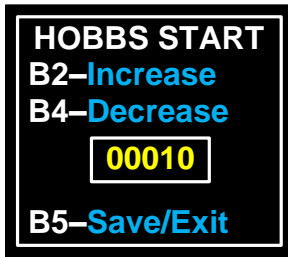

Hobbs hour setup screen. Used to set the Hobbs time when installed in an aircraft with existing flight or engine time.

Page: 23

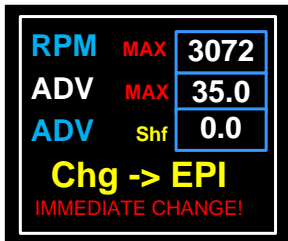

Immediate Change screen: Used to issue RPM, Max Advance, and/or Max Shift changes to the active EPI.

Page: 14

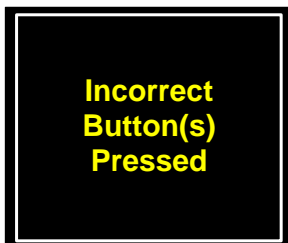

Informational screen: A function button was pressed that has no assigned function or task in the current display screen.

Page: General Error message, not restricted to any menu tree.



Lapse time screen.

Page: 23

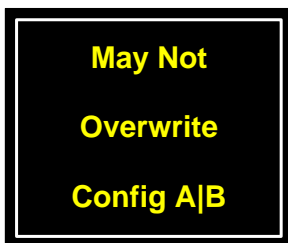

Informational screen: EICommander will not allow the configurations A or B to be overwritten or deleted. This informational screen will be displayed if an On The Fly (OTF) change is attempted without first sending a configuration other than “A” or “B” to the EPIs.

Page: 21

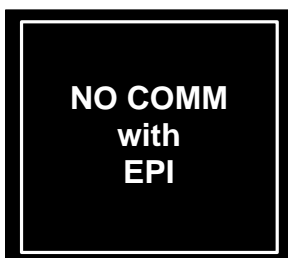

Informational screen: The EICommander could not communicate with one or both EPIs. Verify the wiring and retry the function. In this example the EIC has no Communication with either EPI as indicated by white box around the display. If the EICommander can communicate with only one EPI, the box outlining the display will turn either **Green** (right EPI) or **Red** (Left EPI) to indicate which EPI it is communicating with.

Page: N/A



Informational screen: EICommander cannot communicate with the left EPI.

Page: N/A



Informational screen: EICommander cannot communicate with the right EPI.

Page: N/A

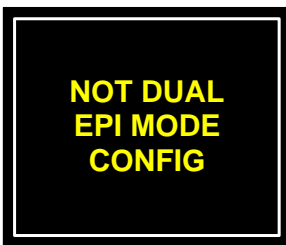

Informational screen: A function was attempted that required two EPIs and the EICommander to be configured for **DUAL** mode.

Page: N/A

Message screen is displayed anytime a Dual Mode feature is requested when the EICommander is not configured for dual EPIs.

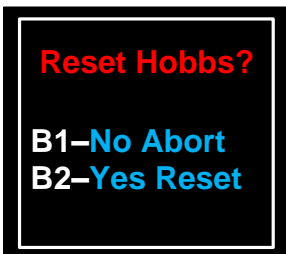

Displayed prior to returning the EICommander to the factory settings. All user selected configuration values including Hobbs reading will be return to Factory Default settings.

Page: 23

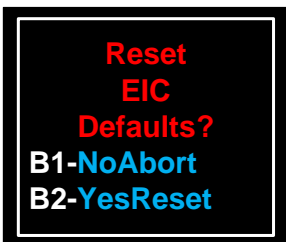

Displayed when the EICommander is instructed to clear the Hobbs meter. If **B2-Yes Reset** is chosen, the current Hobbs value will be erased from the EICommander's memory.

Page: 23

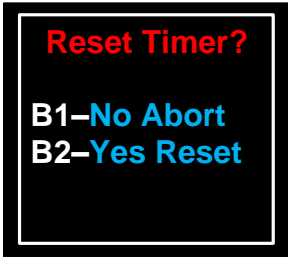

Reset Event Timer menu.

Page: 28



Reset event timer screen.

Page: 28

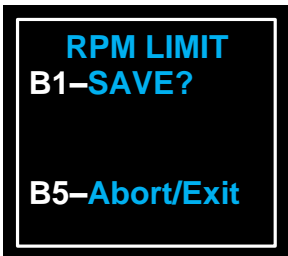

RPM limiter confirmation screen. Press **B1-Save** to save the current RPM limits to the EICommander's memory or press **B5-Abort/Exit** to exit the screen without saving the previously entered limits.

Page: 25

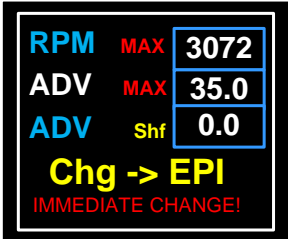

OTF screen: On the fly screen. Changes made in this screen will immediately change the values on the EPI.

Page: 22

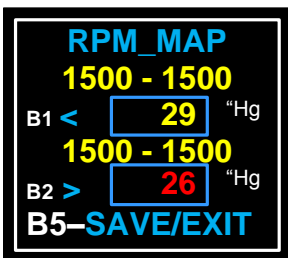

RPM_MAP Alarm set screen: Set the manifold pressure limits to trigger the LED alarm.

Page: 25

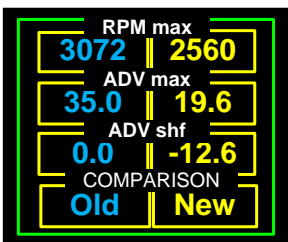

B2-ConfSave screen: Display the current and On The Fly (OTF) proposed settings prior to selecting their disposition as shown on the next CONF ACTION screen.

Page: 22

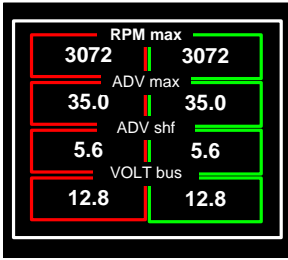

Data retrieval and display screen 2. Displays the configurable elements retrieved from two EPIs. Maximum RPM at which point the EPIs will stop firing the sparkplugs, maximum allowable advance, advance shift, internal voltage.

Page: 21



Tachometer setup screen.

Page: 23

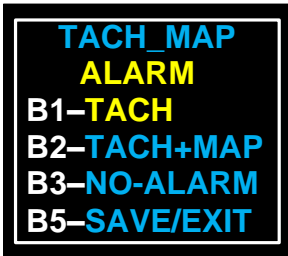

Tachometer and Manifold Pressure Alarm menu.

Page: 24

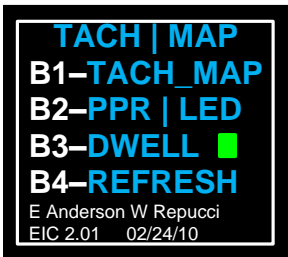

RPM limit and Manifold Pressure menu.

Note: The great flashing box to the right of “B3-DWELL” indicates the “BootLoader” software is installed on the unit.

Page: 23

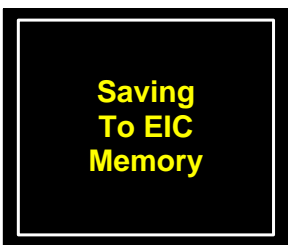

Informational screen: EICommander is pausing to save data to the internal memory.

Displayed after each save operation.



Informational screen: The EICommander is in the process of saving a timing configuration to its internal memory.

Page: 21



Informational screen: The EICommander is in the process of sending a timing configuration to one or both EPIs. In this example the EIC is sending an update to both EPIs, as indicated by white box around display. If sending updates to only one EPI, the white box around display will turn either **Green** (right EPI) or **Red** (Left EPI).

Page: 21



Screen Dwell screen: Set the amount of time to remain on a screen before returning to the tachometer screen.

Page: 25



Hobbs meter setup menu.

Page: 23



Pulses per revolutions and LED caution light setup screen.

Page: 23

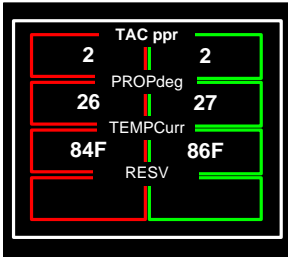

Data retrieval and display screen 3. Displays the configurable elements retrieved from two EPIs. Pulses per revolution for the tachometer signal output, current position of the propeller in degrees, current temperature, and reserved for future use.

Page: 21

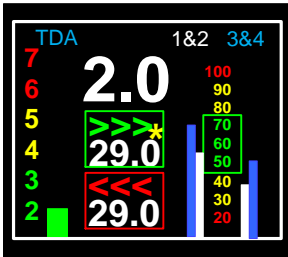

Preflight screen indicating the timing divergence is 2.0 degrees or less and one of the two sparkplugs connected to coil pack 1&2 on the right EPI should be inspected for possible lead fouling.

Page: 29

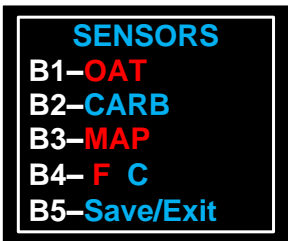

Temperature and temperature probe setup menu.

Page: 27

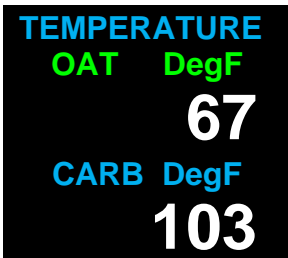

Outside Air Temperature (OAT) and carburetor temperature display screen.

Page: 29



Informational screen: The timing difference between the two installed and configured EPIs is greater than six (6) degrees.

Page: 20

Notes

2.01e Release Notes

1. Added note regarding broken wire and the TDA Alarm
2. Added current advance to the TDA Screen
3. Added Manifold Pressure and associated alarms/warnings
4. Changed text color to white for better sunlight readability
5. Increased RPM and MAP font sizes
6. Resolved various display bugs, including eliminating display flicker
7. Improved Hobbs count routine and changed to 1/10ths of an hour
8. Improved number acceleration for setting limits on RPM, MAP, and Hobbs
9. Improved the timing configuration naming routine
10. Added bootloader green box indicator to the TACH|MAP screen
11. Added improved wiring diagrams to the manual
12. Corrected left / right coil pack health display error
13. Corrected errors on page 28, B5-OPS menu flow.
14. Added List of possible triggers for the TDA alarm.
15. Added TDC Verification section.
16. Updated the Bootloader Wiring Harness Diagram. (Corrected grounding pin out.)