

AeroPower USB Charging Port Installation Instructions

For

BendixKing[®]

AeroPower USB Charging Port
Installation Instructions

Document Number

600840-000055

Last Revised

7 January 2019

Rev

1.0

Sheet

1 of 13

AeroPower USB Charging Port

This document is applicable to the BendixKing AeroPower USB Charging Port.

Honeywell International Inc., 9201-B San Mateo Blvd NE, Albuquerque, NM 87113 USA.

Visit us on the web at www.bendixking.com.
Questions? E-mail us at techsupport@bendixking.com.

AeroPower documentation location – dealers.bendixking.com/dealer-portal/login or Honeywell Tech Pubs at myaerospace.honeywell.com

©2019 Appareo Systems, LLC.
Parts of this document ©2019 BendixKing.
All Rights Reserved.

Table of Contents

1. About AeroPower USB Charging Port	6
1.1. Overview	6
1.2. TSO compliance	6
1.3. TSO deviations	6
1.4. Environmental qualifications	6
1.5. Equipment specifications	6
1.6. Required tools	7
1.7. Supplied hardware	7
1.8. Unpacking/inspection requirements	7
1.9. Limitations for installation	7
1.10. Circuit protective device marking	7
2. Mounting AeroPower USB Charging Port	8
3. Wiring AeroPower USB Charging Port	9
4. Troubleshooting	11
Technical Assistance	11
Appendix A	12

List of Figures

Figure 1: Mounting location	8
Figure 2: Installing AeroPower USB Charging Port	9
Figure 3: Harness	10
Figure 4: Back of AeroPower	10

List of Tables

Table 1: TSO compliance	6
Table 2: TSO deviations	6
Table 3: Equipment specifications	7
Table 4: Required tools	7
Table 5: Supplied hardware	7
Table 6: Pin assignments	9
Table 7: DO-160G tests performed	13

Record of Revision

Revision Number	Change Description	Revision Date	Inserted By
1.0	Initial Release	1/7/19	VJMJ

Related Documentation

Document Number	Title
600845-000029	AeroPower USB Charging Port Maintenance Manual
FAA AC 43.13-1B	Acceptable Methods, Techniques, and Practices - Aircraft Inspection and Repair
FAA AC 43.13-2B	Acceptable Methods, Techniques, and Practices - Aircraft Alterations
FAA TSO-C71	Airborne Static ("DC to DC") Electrical Power Converter (For Air Carrier Aircraft)
RTCA DO-160G	Environmental Conditions and Test Procedures for Airborne Equipment

1. About AeroPower USB Charging Port

1.1. Overview

AeroPower USB Charging Port is a dual 2.1 amp USB charging hub used to power and charge electronic devices in the cockpit.

1.2. TSO compliance

AeroPower USB Charging Port is compliant with the following Technical Standard Order:

Reference/Issue	Title
FAA TSO-C71	Airborne Static ("DC to DC") Electrical Power Converter (For Air Carrier Aircraft)

Table 1: TSO compliance

1.3. TSO deviations

TSO	Section	Deviation
TSO-C71	Subpart B	Environmental qualification testing was performed to DO-160G, not DO-60.

Table 2: TSO deviations

1.4. Environmental qualifications

AeroPower is tested to DO-160G. The AeroPower Environmental Qualification form is found in Appendix A of this document.

1.5. Equipment specifications

Characteristic	Specification
Width	1.848 inches (46.95 mm)
Height	1.848 inches (46.95 mm)
Depth*	1.391 inches (35.32 mm)
AeroPower Unit Weight	0.16 lbs. (.07 kg)
Operational Temperature Range	-20°C to +55°C
Input Voltage Range	10 to 32 VDC
Nominal Current Draw	<25 mA at 14 V and 28 V with no USB connections 0.95 A at 28 V at full output load on both ports 1.9 A at 14 V at full output load on both ports
Power Input	0.7 W with no USB connections 26.25 W max at full output load on both ports

Output Voltage Range	5.0 VDC +/- 0.25 V
Max Current Output	2.5 A per port
Power Output	25 W

*includes mating connector, excludes bend radius

Table 3: Equipment specifications

1.6. Required tools

The following tools are needed for installation of AeroPower.

Tool	Part Number	Used For
1 ¼ inch drill bit	--	Drilling hole in instrument panel
Multimeter	--	Measuring output power and polarity
Crimp tool	0640160201	Power connectors

Table 4: Required tools

1.7. Supplied hardware

Item	Part Number	Quantity
AeroPower Assembly	89000031-001	1
AeroPower Panel Cover		1
Screw		2
Power Connector Receptacle		1
Connector Terminals		2

Table 5: Supplied hardware

1.8. Unpacking/inspection requirements

When unpacking AeroPower, visually inspect for any damage to the unit or missing components. If damage or missing parts are present, contact BendixKing.

1.9. Limitations for installation

This article meets the minimum performance and quality control standards required by a technical standard order (TSO). If you are installing this article on or in a specific type or class of aircraft, you must obtain separate approval for installation.

1.10. Circuit protective device marking

Ensure that the circuit protective device marking is in accordance with AC 43.13-2B, Chapter 2, Section 207, Sub-Section f., Paragraph (1).

2. Mounting AeroPower USB Charging Port

NOTE: AeroPower is only compatible with a panel thickness of .040" to .125".

1. Disconnect aircraft power.
2. Locate an area in the panel to mount AeroPower USB Charging Port. The location must provide adequate clearance in the front and back of the unit based on the dimensions given in Table 3.

ATTENTION: Process may result in metal shavings. Ensure that they do not fall behind the aircraft panel.

3. Drill out a circle in the mounting location with a 1 ¼ inch drill bit using the measurements in Figure 1. Then, cut the notch in the top of the hole.

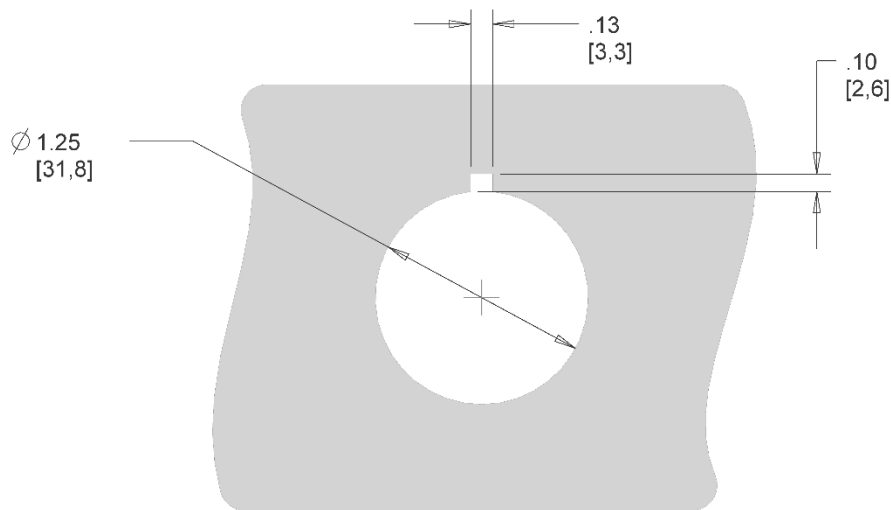

Figure 1: Mounting location

4. Place the AeroPower unit behind the panel and align the front of the unit with the hole. Place the panel cover over the front of the unit and secure with screws.

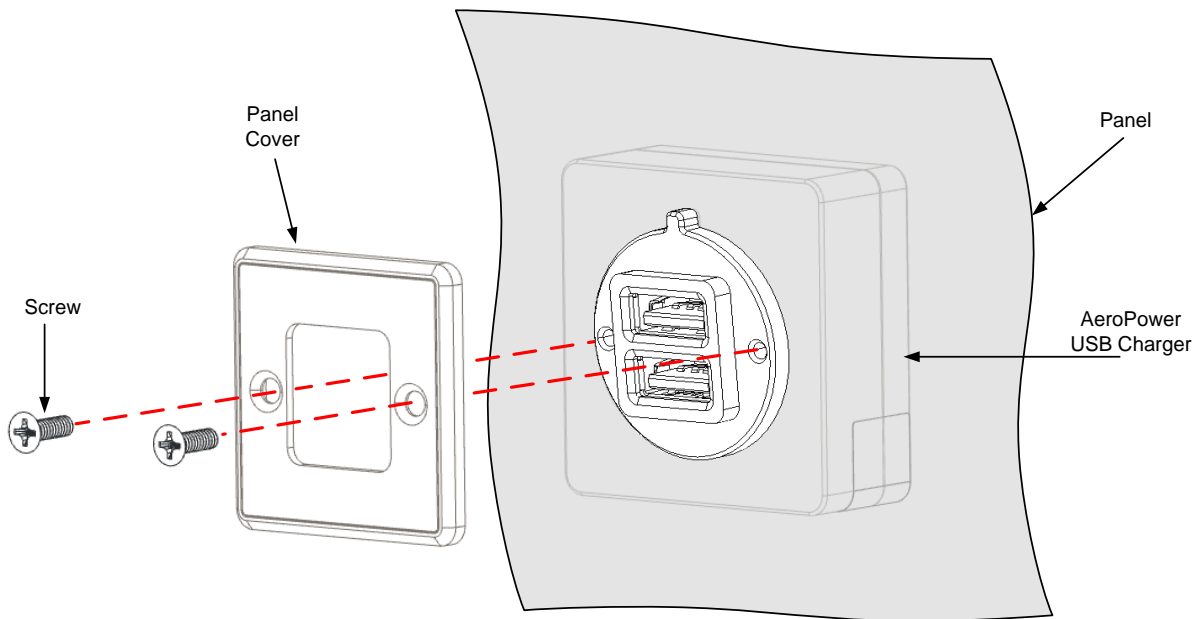

Figure 2: Installing AeroPower USB Charging Port

3. Wiring AeroPower USB Charging Port

The installer must supply 20-24 gauge wiring and install it in accordance with FAA AC 43.13-1B and AC 43.13-2B. Wire length and routing will vary by installation.

The installer must also supply a circuit protective device for use with AeroPower USB Charging Port. Use a 2A breaker for 28V aircraft and a 4A breaker for 14V aircraft.

1. Wire AeroPower according to the diagrams below. Provide a service loop.

Pin #	Pin Name	Description
1	Power	10-32 VDC
2	Ground	--

Table 6: Pin assignments

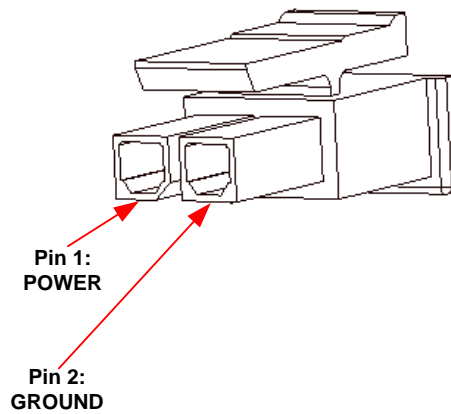

Figure 3: Harness

2. Verify input power and polarity.
 - a. Connect aircraft power and ensure that the breaker is pushed in.
 - b. On the power harness, place the negative probe of a multimeter on Pin 2 and the positive probe on Pin 1.
 - c. Measure the voltage across the two wires using a multimeter. The voltage reading should be equal to your aircraft power.
 - d. Disconnect aircraft power.
3. Connect the power receptacle into the header on the back of AeroPower USB Charging Port.

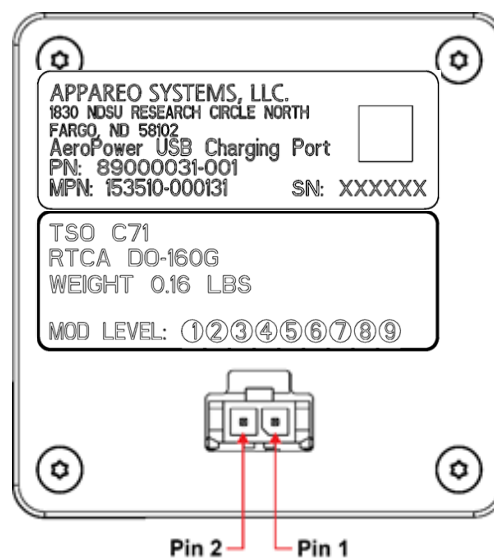

Figure 4: Back of AeroPower

4. Connect aircraft power and ensure that the breaker is pushed in.
5. Verify the voltage output of AeroPower before connecting any devices.

4. Troubleshooting

Problem	Troubleshooting Steps
AeroPower is not powering a device.	<ul style="list-style-type: none">• Verify that the circuit protective device is functioning correctly.• Verify that the polarity on the power connector is correct.

Technical Assistance

For support, please contact BendixKing at techsupport@bendixking.com

Appendix A

Nomenclature: AeroPower USB Charging Port

Part number: 89000031-001

Manufacturer Part number: 153510-000131

TSO number: TSO-C71

Manufacturer: Appareo Systems

Address: 1830 NDSU Research Circle North, Fargo, ND 58102, USA

Conditions	DO-160G Section	Description of tests conducted
Temperature and Altitude	4.0	
Short-Time Operating Low Temperature	4.5.1	Equipment tested to Category F1.
Operating Low Temperature	4.5.2	Equipment tested to Category F1.
Short-Time Operating High Temperature	4.5.3	Equipment tested to Category F1.
Operating High Temperature	4.5.4	Equipment tested to Category F1.
In-Flight Loss of Cooling	4.5.5	Equipment identified as Category X, no test performed.
Altitude	4.6.1	Equipment tested to Category F1.
Decompression	4.6.2	Equipment identified as Category X, no test performed.
Overpressure	4.6.3	Equipment identified as Category X, no test performed.
Temperature Variation	5.0	Equipment tested to Category C.
Humidity	6.0	Equipment tested to Category A.
Operational Shocks and Crash Safety	7.0	
Operational Shocks	7.2	Equipment tested to Category B. 11ms duration.
Crash Safety	7.3	Equipment tested to Category B. Aircraft type: 5R
Vibration	8.0	
Fixed Wing Aircraft Standard Vibration	8.5	Equipment tested to Category S. Curve M.

Sine-on-Random for Category U	8.8.2	Equipment tested to Category U. Curve G.
Explosive Atmosphere	9.0	Equipment identified as Category X, no test performed.
Waterproofness	10.0	Equipment identified as Category X, no test performed.
Fluids Susceptibility	11.0	Equipment identified as Category X, no test performed.
Sand and Dust	12.0	Equipment identified as Category X, no test performed.
Fungus Resistance	13.0	Equipment identified as Category X, no test performed.
Salt Fog	14.0	Equipment identified as Category X, no test performed.
Magnetic Effect	15.0	Equipment tested to Category Y.
Power Input	16.0	
Normal Operating Conditions (dc)	16.6.1	Equipment tested to Category BXX.
Voltage (average value dc)	16.6.1.1	Equipment tested to Category BXX.
Abnormal Operating Conditions (dc)	16.6.2	Equipment tested to Category BXX.
Voltage Spike	17.0	Equipment tested to Category B.
Audio Frequency Conducted Susceptibility	18.0	Equipment tested to Category B.
Induced Signal Susceptibility	19.0	Equipment identified as Category X, no test performed.
Radio Frequency Susceptibility	20.0	Equipment identified as Category X, no test performed.
Emission of Radio Frequency Energy	21.0	Equipment tested to Category B.
Lightning Induced Transient Susceptibility	22.0	Equipment identified as Category X, no test performed.
Lightning Direct Effects	23.0	Equipment identified as Category X, no test performed.
Icing	24.0	Equipment identified as Category X, no test performed.
Electrostatic Discharge	25.0	Equipment tested to Category A.
Fire, Flammability	26.0	Equipment identified as Category X, no test performed.

Table 7: DO-160G tests performed