

EXCELERON DAYLITE™

TAXI - P/N: AVE-EX9TZYW-ENA
LANDING - P/N: AVE-EX9LZYW-ENA

Landing or Taxi LED light



Specification

Dimensions (mm):	83,3 mm x 47,2 mm x 37 mm
Dimensions (inches):	3.280" x 1.860" x 1.457"
Weight:	220g / 7.76 oz
Operating Voltage Range:	9 – 18 VDC
Input Current (@14V):	1.5 A (+/-5%)
Output Power:	18 W
Ambient Temperature:	from -40°C to +85°C from -40°F to +185°F
Overheat Protection:	YES
Taxi Lens – Viewing Angle:	40° x 20°
Landing Lens – Viewing Angle:	12°
Waterproof, Dust-proof, Shock-proof, Vibration-proof:	YES

Drawing

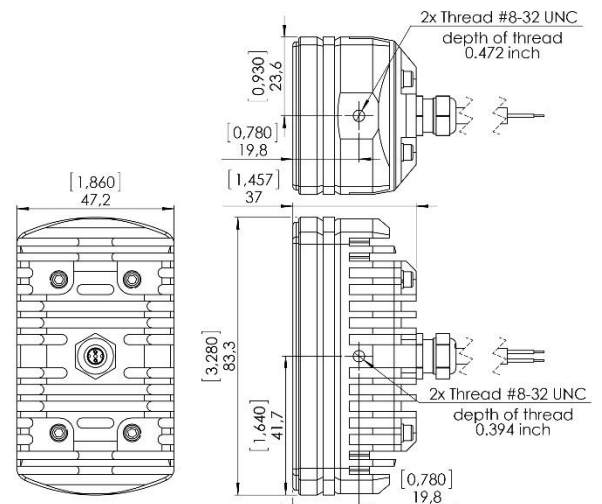

Wiring Diagram

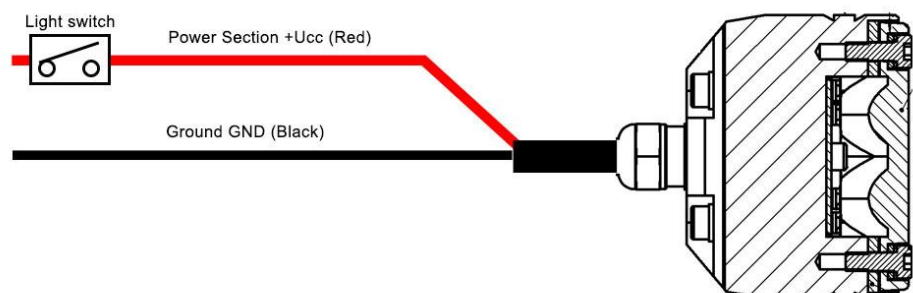

**NOT APPROVED FOR INSTALLATION ON CERTIFIED AIRCRAFT
THIS IS NOT A TSO CERTIFIED LIGHT**