

PART-66 SYLLABUS LEVELS
 CERTIFICATION CATEGORY → B1 B2

Sub-Module 12
DC MOTOR/GENERATOR THEORY
 Knowledge Requirements

3.12 - DC Motor/Generator Theory

- Basic motor and generator theory;
- Construction and purpose of components in DC generator;
- Operation of, and factors affecting output and direction of current flow in DC generators;
- Operation of, and factors affecting output power, torque, speed and direction of rotation of DC motors;
- Series wound, shunt wound and compound motors;
- Starter Generator construction.

| | B1 | B2 |
|--|----|----|
| | 2 | 2 |

Level 2

A general knowledge of the theoretical and practical aspects of the subject and an ability to apply that knowledge.

Objectives:

- (a) The applicant should be able to understand the theoretical fundamentals of the subject.
- (b) The applicant should be able to give a general description of the subject using, as appropriate, typical examples.
- (c) The applicant should be able to use mathematical formula in conjunction with physical laws describing the subject.
- (d) The applicant should be able to read and understand sketches, drawings and schematics describing the subject.
- (e) The applicant should be able to apply his knowledge in a practical manner using detailed procedures.

DC GENERATORS AND CONTROLS

DC generators transform mechanical energy into electrical energy. As the name implies, DC generators produce direct current and are typically found on light aircraft. In many cases, DC generators have been replaced with DC alternators.

Both devices produce electrical energy to power the aircraft's electrical loads and charge the aircraft's battery. Even though they share the same purpose, the DC alternator and DC generator are very different. DC generators require a control circuit in order to ensure the generator maintains the correct voltage and current for the current electrical conditions of the aircraft. Typically, aircraft generators maintain a nominal output voltage of approximately 14 volts or 28 volts.

GENERATORS

The principles of electromagnetic induction are key to understanding generator operation. When lines of magnetic force are cut by a conductor passing through them, voltage is induced in the conductor. The strength of the induced voltage is dependent upon the speed of the conductor and the strength of the magnetic field. If the ends of the conductor are connected to form a complete circuit, a current is induced in the conductor. The conductor and the magnetic field make up an elementary generator.

This simple generator is illustrated in *Figure 12-1*, together with the components of an external generator circuit which collect and use the energy produced by the simple generator. The loop of wire (*A and B of Figure 12-1*) is arranged to rotate in a magnetic field. When the plane of the loop of wire is parallel to the magnetic lines of force, the voltage induced in the loop causes a current to flow in the direction indicated by the arrows in *Figure 12-1*. The voltage induced at this position is maximum, since the wires are cutting the lines of force at right angles and are thus cutting more lines of force per second than in any other position relative to the magnetic field.

As the loop approaches the vertical position shown in *Figure 12-2*, the induced voltage decreases because both sides of the loop (*A and B*) are approximately parallel to the lines of force and the rate of cutting is reduced. When the loop is vertical, no lines of force are cut since

the wires are momentarily traveling parallel to the magnetic lines of force, and there is no induced voltage.

As the rotation of the loop continues, the number of lines of force cut increases until the loop has rotated an additional 90° to a horizontal plane. As shown in *Figure 12-3*, the number of lines of force cut and the induced voltage once again are maximum. The direction of cutting, however, is in the opposite direction to that occurring in *Figures 12-1* and *12-2*, so the direction (polarity) of the induced voltage is reversed.

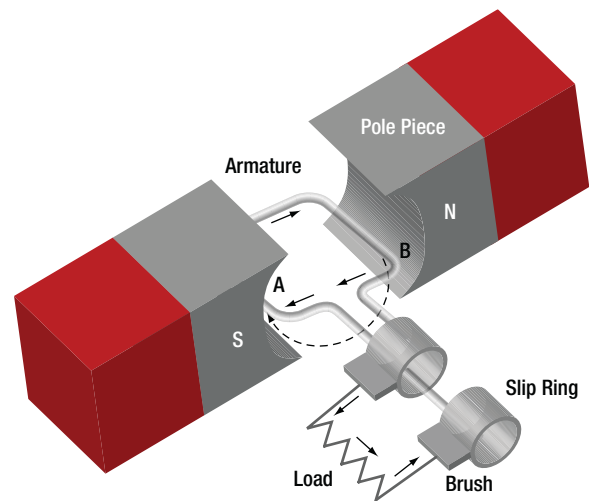

Figure 12-1. Inducing maximum voltage in an elementary generator.

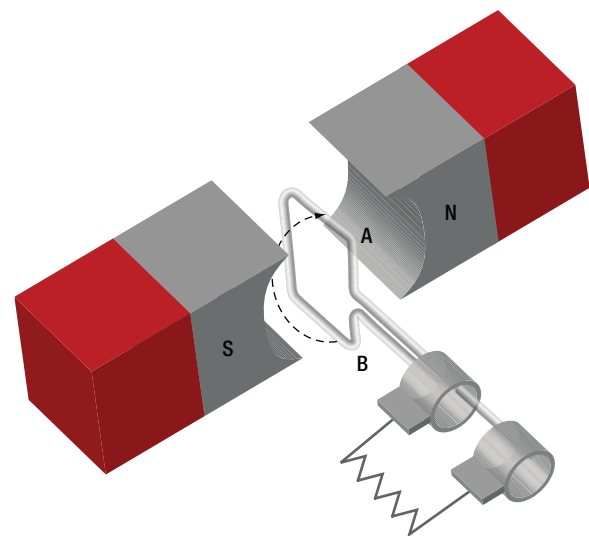

Figure 12-2. Inducing minimum voltage in an elementary generator.

As rotation of the loop continues, the number of lines of force having been cut again decreases, and the induced voltage becomes zero at the position shown in *Figure 12-4*, since the wires A and B are again parallel to the magnetic lines of force.

These principles show that voltage is induced in the armature of a generator throughout the entire 360° rotation of the conductor. The armature is the rotating portion of a DC generator. As shown, the voltage being induced is AC. (*Figure 12-5*)

Since the conductor loop is constantly rotating, some means must be provided to connect this loop of wire to the electrical loads. As shown in *Figure 12-6*, slip rings

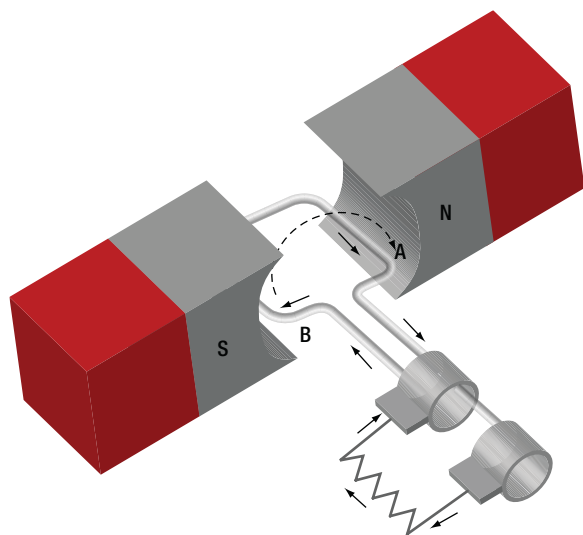

Figure 12-3. Inducing maximum voltage in the opposite direction.

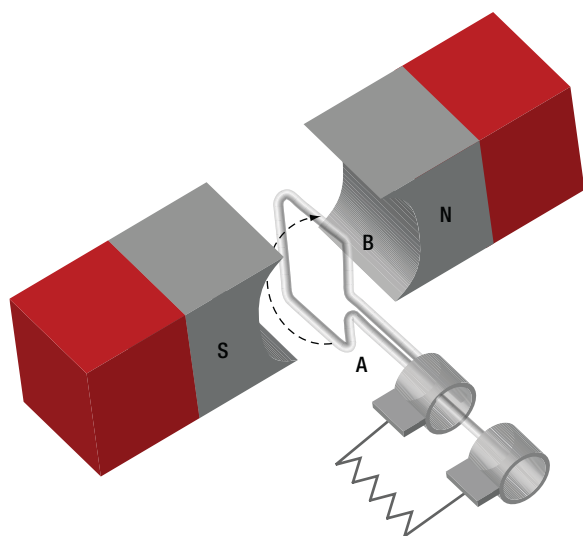

Figure 12-4. Inducing a minimum voltage in the opposite direction.

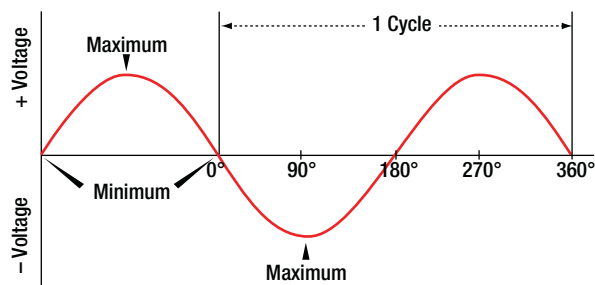

Figure 12-5. Output of an elementary generator.

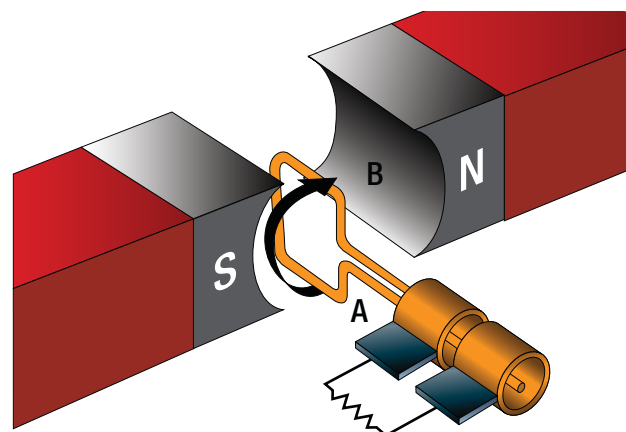

Figure 12-6. Generator slip rings and loop rotate; brushes are stationary.

and brushes can be used to transfer the electrical energy from the rotating loop to the stationary aircraft loads. The slip rings are connected to the loop and rotate; the brushes are stationary and allow a current path to the electrical loads. The slip rings are typically a copper material and the brushes are a soft carbon substance.

It is important to remember that the voltage being produced by this basic generator is AC, and AC voltage is supplied to the slip rings. Since the goal is to supply DC loads, some means must be provided to change the AC voltage to a DC voltage. Generators use a modified slip ring arrangement, known as a commutator, to change the AC produced in the generator loop into a DC voltage. The action of the commutator allows the generator to produce a DC output.

By replacing the slip rings of the basic AC generator with two half cylinders (the commutator), a basic DC generator is obtained. In *Figure 12-7*, the red side of the coil is connected to the red segment and the amber side of the coil to the amber segment. The segments are insulated from each other. The two stationary brushes are placed on opposite sides of the commutator and are so mounted that each brush contacts each segment of the

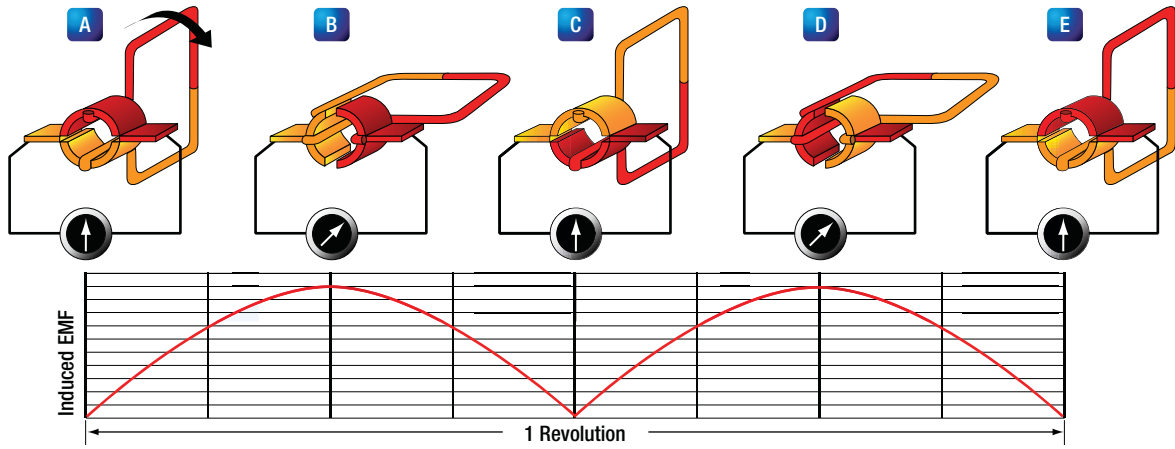

Figure 12-7. A two-piece slip ring, or commutator, allows brushes to transfer current that flows in a single direction (DC).

commutator as the commutator revolves simultaneously with the loop. The rotating parts of a DC generator (coil and commutator) are called an armature.

additional loop in the rotor, another two commutator segments is required. A photo of a typical DC generator commutator is shown in *Figure 12-9*.

As seen in the very simple generator of *Figure 12-7*, as the loop rotates the brushes make contact with different segments of the commutator. In positions A, C, and E, the brushes touch the insulation between the brushes; when the loop is in these positions, no voltage is being produced. In position B, the positive brush touches the red side of the conductor loop. In position D, the positive brush touches the amber side of the armature conductor. This type of connection reversal changes the AC produced in the conductor coil into DC to power the aircraft. An actual DC generator is more complex, having several loops of wire and commutator segments.

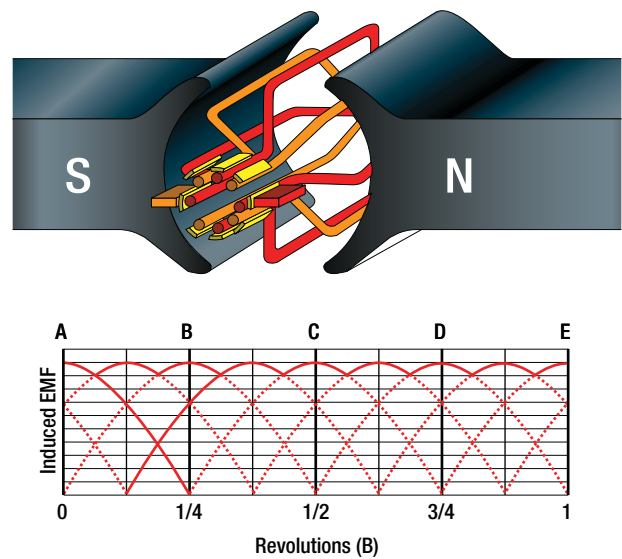

Figure 12-8. Increasing the number of coils reduces the ripple in the voltage.

Because of this switching of commutator elements, the red brush is always in contact with the coil side moving downward, and the amber brush is always in contact with the coil side moving upward. Though the current actually reverses its direction in the loop in exactly the same way as in the AC generator, commutator action causes the current to flow always in the same direction through the external circuit or meter. The voltage generated by the basic DC generator in *Figure 12-7* varies from zero to its maximum value twice for each revolution of the loop. This variation of DC voltage is called ripple and may be reduced by using more loops, or coils, as shown in *Figure 12-8*.

As the number of loops is increased, the variation between maximum and minimum values of voltage is reduced (*Figure 12-8*), and the output voltage of the generator approaches a steady DC value. For each



Figure 12-9. Typical DC generator commutator.

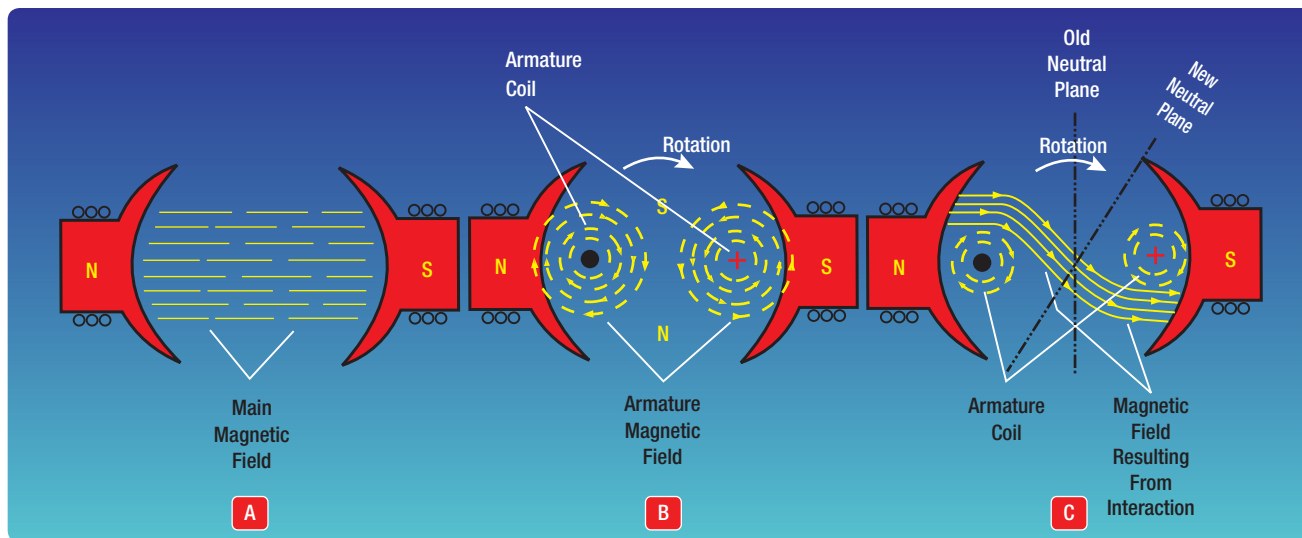

Figure 12-10. Armature reaction.

ARMATURE REACTION

Armature reaction is a phenomenon that occurs as a result of magnetic flux produced by the armature windings when armature current flows. This armature magnetic flux interferes with the main generator field flux, distorting and weakening it. The effect is that the main field poles are off-set from their correct axes, planes, or positions. The DC Generator becomes inefficient. Also a further result from armature reaction is brush sparking on the commutator, because the main field poles planes are shifted without a corresponding shift of brush positions. (Figure 12-10)

Armature reaction increases as generator load is increased from the corresponding increase in armature current. Armature reaction is countered by two methods:

COMPENSATING WINDINGS

Compensation windings are coils connected in series with the armature coils and are situated between the main pole faces. A magnetic field is produced in direct proportion to armature current. The compensating windings are wound so that their magnetic field opposes the armature magnetic field, and hence cancel armature reaction. The main generator field poles will remain in their respective positions for all values of armature current, that is under varying loads.

INTERPOLES

Interpoles are additional poles placed between the main poles. Each pole is wound with a small number of large wire coil turns, connected in series with the armature. They are placed so that each interpole has the same

magnetic polarity as the immediate main pole in the direction of rotation. Interpoles are wound, similar to compensating windings, to oppose any shift of the main poles from armature reaction.

ARMATURE RESISTANCE

Armature resistance (the relatively small ohmic resistance of armature windings) creates a small voltage drop across the armature which reduces the output or terminal voltage available to the generator load. A shunt wound DC generator will show a characteristic of the terminal voltage dropping with load increase. This is caused by armature reaction (which cannot be completely overcome), and armature resistance. (Figure 12-11)

A-B is the no-load terminal voltage; A-C and A-D shows the drop in terminal voltage from the effects of Armature Reaction and Armature Resistance respectively.

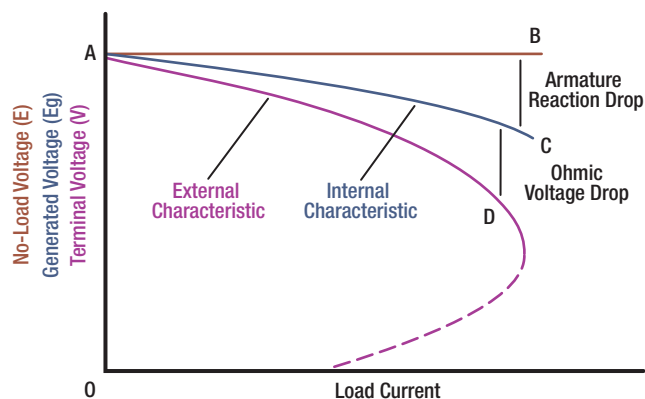

Figure 12-11. Characteristics of a DC shunt generator.