

Installation Manual and Operating Instructions

Model T11200 Series
Static Electrical Power Inverter



True Blue Power® is a division of Mid-Continent Instrument Co., Inc.

Mid-Continent Instrument Co., Inc.
dba Mid-Continent Instruments and Avionics
9400 E. 34th Street N.
Wichita, KS 67226

Manual Number 9017680
Rev F, February 27, 2017

FOREWORD

This manual provides information intended for use by persons who, in accordance with current regulatory requirements, are qualified to install this equipment. If further information is required, please contact:

True Blue Power
c/o Mid-Continent Instrument Co., Inc.
Attn: Customer Service Dept.
9400 E. 34th Street N.
Wichita, KS 67226 USA
PH (316) 630-0101
FX (316) 630-0723
www.truebluepowerusa.com
www.mcico.com

We welcome your comments concerning this manual. Although every effort has been made to keep it free of errors, some may occur. When reporting a specific problem, please describe it briefly and include the manual part number, the paragraph/figure/table reference and the page number. Send your comments to:

True Blue Power
c/o Mid-Continent Instrument Co., Inc.
Attn: Technical Publications
9400 E. 34th Street N.
Wichita, KS 67226 USA
PH (316) 630-0101
FX (316) 630-0723

All products produced by Mid-Continent Instrument, Co., Inc., including those identified as Mid-Continent Instruments and Avionics or True Blue Power, are designed and manufactured in Wichita, KS, USA.

© Copyright 2017
Mid-Continent Instrument Co., Inc.

REVISION DETAIL

<u>Rev.</u>	<u>Date</u>	<u>Approved</u>	<u>Detail</u>
A	04/27/12	JRC	Initial release.
B	07/23/12	JDS	Page 9; view overlaps. Page 15 (TS) and (TDS) 501 was 500.
C	01/02/15	BMC	Added T11202 model.
D	08/08/16	VAA	Added 6431200-5 model.
E	12/30/16	KJW	Added the -2, -4, and -5 to Table 1.1.
F	2/27/17	JRC	Added 6431200-6 model. Add capacitor/noise section. General update to entire manual.

TABLE OF CONTENTS

SECTION 1	GENERAL DESCRIPTION	
1.1	INTRODUCTION	5
1.2	TECHNICAL SPECIFICATIONS	5
SECTION 2	PRE-INSTALLATION CONSIDERATIONS	
2.1	COOLING	7
2.2	EQUIPMENT LOCATION	7
2.3	ROUTING OF CABLES	7
2.4	LIMITATIONS	7
SECTION 3	INSTALLATION PROCEDURES	
3.1	GENERAL INFORMATION	8
3.2	UNPACKING AND INSPECTING EQUIPMENT	8
3.3	CABLE HARNESS	8
3.3.1	Wire Gauge Selection	8
3.3.2	Pin Assignment Information	8
3.3.2.1	Input Power	8
3.3.2.2	Inverter Output	9
3.3.2.3	Circuit Breakers on Inverter Output	9
3.3.2.4	Remote ON/OFF Enable	9
3.3.3	Considerations for use with GFI and Noisy Electronics	11
3.3.4	Harness Verification	11
3.4	MOUNTING	11
3.5	INSTALLATION CAUTIONS	11
3.6	INSTALLATION COMPLETION	11
SECTION 4	OPERATION	
4.1	ELECTRICAL PERFORMANCE	13
4.2	PROTECTIVE FEATURES	14
4.2.1	Remote ON/OFF	14
4.2.2	Over-Voltage	14
4.2.3	Under-Voltage	14
4.2.4	Over-Temperature	14
4.2.5	Short Circuit and Over-Current for the 6431200-1, -2, -3, -5, and -6	14
4.2.6	Short Circuit, Over-current, and Installation for the 6431200-4	15
4.2.7	Temperature Regulated Cooling	15
SECTION 5	CONFORMANCE	
5.1	CONTINUED AIRWORTHINESS STATEMENT	16
5.2	ENVIRONMENTAL QUALIFICATION STATEMENT	16
NUMBER	LIST OF TABLES AND FIGURES	
1.1	TI1200 Model Variations	5
1.2	Electrical Attributes	5
1.3	Physical Attributes	6
1.4	Qualification	6
3.3	Connector Pinout Figure	9
3.3	Connector Pinout Table	9
3.4	Example Wiring Diagrams	10
3.5	TI1200 Series Outline Drawing	12
4.1	Output Power Performance Vs Temperature	13
4.2	Output Power Performance Vs Input Voltage	13
4.3	Output Power Performance Vs Altitude	14

SECTION 1 GENERAL DESCRIPTION

1.1 INTRODUCTION

The model TI1200 Series Static Electrical Power Inverter is a lightweight power converter that translates a 20 to 36 VDC input to a variety of application options:

Model	Part Number	Output	Typical Application
TI1200	6431200-1	115 VAC, 60 Hz	General Purpose 115V cabin power
TI1200	6431200-2	115 VAC, 60 Hz	Edge Mount, non-TSO
TI1202	6431200-3	230 VAC, 50 Hz	General purpose 230V cabin power
TI1200	6431200-4	115 VAC, 60 Hz	High-peak power microwave ovens/coffee makers
TI1202	6431200-5	230 VAC, 50 Hz, 600VA	For aircraft with power-limited electrical systems
TI1204	6431200-6	115 VAC, 400 Hz	General Purpose 400Hz aircraft power

Table 1.1: TI1200 Model Variations

All configurations of the Model TI1200 Series provide 1200 watts (VA) of power except the 6431200-5 which is adjusted to limit output to 600VA. The alternating current output is defined as a pure sine wave with typically less than 2.5% of total harmonic distortion for clean, noise-free, harmonic-free power to supply loads of corresponding voltage, power and frequency. For the TI1200, the 115VAC 60 Hertz (Hz) is suitable for nearly any common commercial or consumer load rated for a nominal input of 115VAC. The TI1202 is designed for a 230VAC output with an AC frequency of 50 Hz for international equipment. The TI1204 is designed to meet 115VAC 400Hz for aircraft system uses.

The TI1200 Series Static Inverter is FAA certified to TSO C73 and tested to rigorous environmental standards and levels of RTCA DO-160. The small size and light weight in conjunction with its installation flexibility (inside or outside the pressure vessel) make it an ideal choice for aircraft power needs while reducing the challenges associated with other similar products.

Highlighted features include short circuit protection, overload capability, low voltage shut-down, temperature monitoring, a self-resettable over-temperature disable, and a remote on/off function. The rugged extrusion that houses the unit is designed to help dissipate heat and provide mechanical strength against vibration or other possibilities of damage. Two independent fans allow for a smaller unit, quiet operation, and keep the internal components cool extending the life of the unit.

1.2 TECHNICAL SPECIFICATIONS

Electrical Attributes:	6431200-1, 2, 4	6431200-3	6431200-5	6431200-6
Input Voltage:	Rated 28VDC nominal; 20-36VDC certified; see figure 4.2			
Input Power:	60 amps; 0.2A at no load		30 amps; 0.2A at no load	60 amps; 0.2A at no load
Output Voltage:	115VAC $\pm 3\%$ at 60 Hertz $\pm 0.1\%$ (single phase)	230VAC $\pm 3\%$ at 50 Hertz $\pm 0.1\%$ (single phase)		115VAC $\pm 3\%$ at 400 Hertz $\pm 0.1\%$ (single phase)
Output Power:	1200 watts (1200 VA at power factor = 1)		600 watts (600 VA at power factor = 1)	1200 watts (1200 VA at power factor = 1)
Output Waveform:	Pure sine wave			
Power Factor:	-0.8 to +0.8			
Efficiency:	88% nominal			
Total Harmonic Distortion (THD):	< 2.5%	< 3%	< 3.5%	

Table 1.2: Electrical Attributes

Physical Attributes:	6431200-1, 3, 4, 5, 6	6431200-2
Weight:	7.25 pounds max	
Dimensions: (not including connector mate)	12.00 inches long x 6.32 inches wide x 3.45 inches high	
Mating Connector (and cable clamp):	MS3106A24-12S, MS3106E24-12S or equivalent (MCI P/N 9017235)	
Mounting:	Base mount – orientation not critical	Edge mount

Table 1.3: Physical Attributes

Qualifications:	6431200-1, 3, 4, 5, 6
Qualification:	FAA TSO-C73
Environmental Qualification:	RTCA DO-160G Environmental Category F3(Y)S2BB[(RCC1)(UG)]XXXXXXXXZXXXXXBXXXX
Altitude:	-15,000 ft. to +55,000 ft.; See Figure 4.3
Temperature:	-55°C to +70°C (-67°F to +158°F); See Figure 4.1

Table 1.4: Qualifications

SECTION 1 PRE-INSTALLATION CONSIDERATIONS

1.1 COOLING

No external cooling is required. The unit is equipped with two internal DC fans. Restriction to airflow can cause overheating of the unit and limit performance or reduce the expected life of the product. Make sure to provide adequate clearance on both ends of the unit with the hexagonal openings to allow for proper circulation. In general, four to six inches of clearance on both ends of the unit should be acceptable. Mounting the unit to a metal surface can also help reduce the effects of temperature within the unit but is not required.

1.2 EQUIPMENT LOCATION

The TI1200 Series Static Inverter is designed for mounting flexibility, allowing for installation inside or outside the pressure vessel with no requirement for temperature control. In addition to altitude and temperature resistance, the unit is also designed to withstand high levels of condensing humidity.

Installation locations where the unit could be subject to standing or direct water exposure should be avoided. The unit can be mounted in any orientation. Clearance should be provided for the mating connector and may require as much as five inches past the unit connector to allow for back shell access to the connector.

1.3 ROUTING OF CABLES

The wires and cable bundle associated with the unit are heavy gauge wire and carry significant power. Be aware of routing cables near other electronics or with other wire bundles that may be susceptible to high energy flow.

Avoid sharp bends in cabling and routing near aircraft control cables. Also avoid proximity and contact with aircraft structures, avionics equipment, or other obstructions that could chafe wires during flight and cause undesirable effects.

1.4 LIMITATIONS

The TI1200 Series of static electric power inverters is certified to FAA TSO-C73 with the following limitations identified:

- 1) Alternating current (AC) output is provided at 115 volts and 60 Hertz in lieu of 115 volts and 400 Hertz as identified in the MPS of the TSO. This applies to the TI1200 models. Performance complies fully with all tests and requirements of the MPS of the TSO accordingly.
- 2) Alternating current (AC) output is provided at 230 volts and 50 Hertz in lieu of 115 volts and 400 Hertz as identified in the MPS of the TSO. This applies to the TI1202 models.
- 3) Equivalent environmental qualification was verified per RTCA DO-160G in lieu of those identified within the MPS of the TSO.

The conditions and tests for TSO approval of this article are minimum performance standards. Those installing this article, on or in a specific type or class of aircraft, must determine that the aircraft installation conditions are within the TSO standards, specification of the article, and deviations as listed above. TSO articles must have separate approval for installation in an aircraft. The article may be installed only according to 14 CFR part 43 or the applicable airworthiness requirements.

SECTION 2 INSTALLATION PROCEDURES

2.1 GENERAL INFORMATION

This section contains interconnect diagrams, mounting dimensions and other information pertaining to the installation of the TI1200 Series Static Inverter. After installation of cabling and before installation of the equipment, ensure that power is applied only to the pins specified in the interconnect diagram.

2.2 UNPACKING AND INSPECTING EQUIPMENT

When unpacking this equipment, make a visual inspection for evidence of any damage that may have incurred during shipment. The following parts should be included:

- | | |
|-------------------------------------|---------------------------------|
| a. Static Inverter | MCI P/N 6431200-() |
| b. Mating Connector (& cable clamp) | MCI P/N 9017235-1 and 9017235-2 |
| c. Installation Manual | MCI P/N 9017680 |

Equipment not provided:

- | | |
|-----------------------|---|
| a. Mounting Hardware | four (4) 1/4-20 pan head screws
1/4" lock washers (optional) |
| b. Cable Harness Wire | See Section 3.3 for specifications |

2.3 CABLE HARNESS

Construct the cable harness with regards to the instructions below, and using the Connector Pinout of Figure 3.3, Table 3.3, and Wiring Diagram of Figure 3.4.

Refer to Section 2: Pre-Installation Considerations in regards to routing precautions.

2.3.1 Wire Gauge Selection

Use of PTFE, ETFE, TFE, Teflon, or tefzel insulated wire is recommended for aircraft use. Use the following wire gauges for each of the pins in the connector:

- Pin A and C – 8 AWG stranded (see Note below)
- Pin B and D – 14 AWG stranded (see Note below)
- Pin E – 16-24 AWG stranded

Note – Because of lower current requirements, the 600VA 6431200-5 may use 10 AWG for input power and 16 AWG for the AC output.

2.3.2 Pin Assignment Information

2.3.2.1 Input Power:

Positive DC input – +24 to 32 VDC. Connect to the aircraft 28 VDC bus using a 60-70 Amp circuit breaker. (Recommended circuit breaker for the 600VA 6431200-5 is 30 or 35 Amp).

Negative DC input – Internally this pin is connected to the inverter enclosure. Connect to aircraft ground.

Note: Two common practices for the connecting the -28V of power devices in aircraft are:

1. The negative lead connects from the device to the negative power bus.
2. The negative lead connects from the device to the negative power bus, and a second lead connects to the aircraft structure close to the power device.

The TI1200 Series passes DO-160G Section 21 conducted emissions testing using both methods as listed in Section 5.2 of this report.

2.3.2.2 Inverter Output:

AC Output – 115VAC, 60Hz, 400Hz or 230VAC, 50Hz. Used for powering devices where terrestrial/utility power designations are used, pin B can be connected as “Line” or “Hot”.

AC Return – Used for powering devices where terrestrial/utility power designations are used, pin C can be connected as “Neutral”.

2.3.2.3 Circuit Breakers on Inverter Output:

Use of a circuit breaker on the AC output is optional. On 115V versions, a 10 Amp circuit breaker is sufficient for the full inverter 1200VA output (5 Amp single circuit breaker for 230V and 1200VA, 2.5A for 230V and 600VA). For convenience at each AC outlet, individual circuit breakers of 1 to 5 amps each can be used. If a single pole breaker is used, install the breaker on the wire from pin B. If a double pole breaker is installed, route both pins B and D through the circuit breaker.

2.3.2.4 Remote On/Off Control: (also see section 4.2.1)

Remote ON/OFF Enable Control – Connecting this pin to either DC Negative or to aircraft ground will enable the AC output of the inverter. By utilizing a switch between this pin and ground or negative, it will allow remote on/off control of the unit. When unconnected (output is OFF) this pin will have approximately 11 VDC present, internally limited to less than 1 mA. If the inverter is to be enabled at all times, pin E can be connected to pin C.

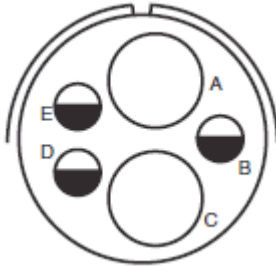

Figure 3.3

Pinout View of
Unit Connector

Connector Pinout	
Pin #	
A	24-32VDC Input
B	VAC Output
C	Input Return
D	Output Return
E	Remote On/Off

Table 3.3

Connector Pinout

2.3.3 Use with GFI, Noisy electronics, and other Earth/Neutral Situations

The TI1200 series of inverters is fully electrically isolated from the DC input as indicated by TSO-C73, and provides a balanced AC output where AC output and AC return are not associated with the inverter case ground. This is different from terrestrial AC systems where Neutral is connected to ground at an AC distribution transformer at the power mains.

Some consumer items contain internal power supplies that require an Earth-Neutral connection for their noise filters to work properly. Similarly, some GFI protection will not function properly if there is not an Earth/Neutral connection or if there is noise between Earth and Neutral.

If consumer video electronics exhibit noise interference, if touch-screen devices exhibit erratic touch-screen operation, or if added GFI systems exhibit false-tripping, then it is recommended to place a capacitor between the inverter AC return (pin D) and the inverter chassis ground or airframe. This capacitor can be located anywhere between the inverter output and the furthest AC outlet. A film capacitor, metalized polyester or metalized polypropylene with a value between 0.047uF and 0.1uF rated for at least 200VAC (for 115VAC inverter output voltage) or 300VAC (for 230VAC inverter output voltage) can be used.

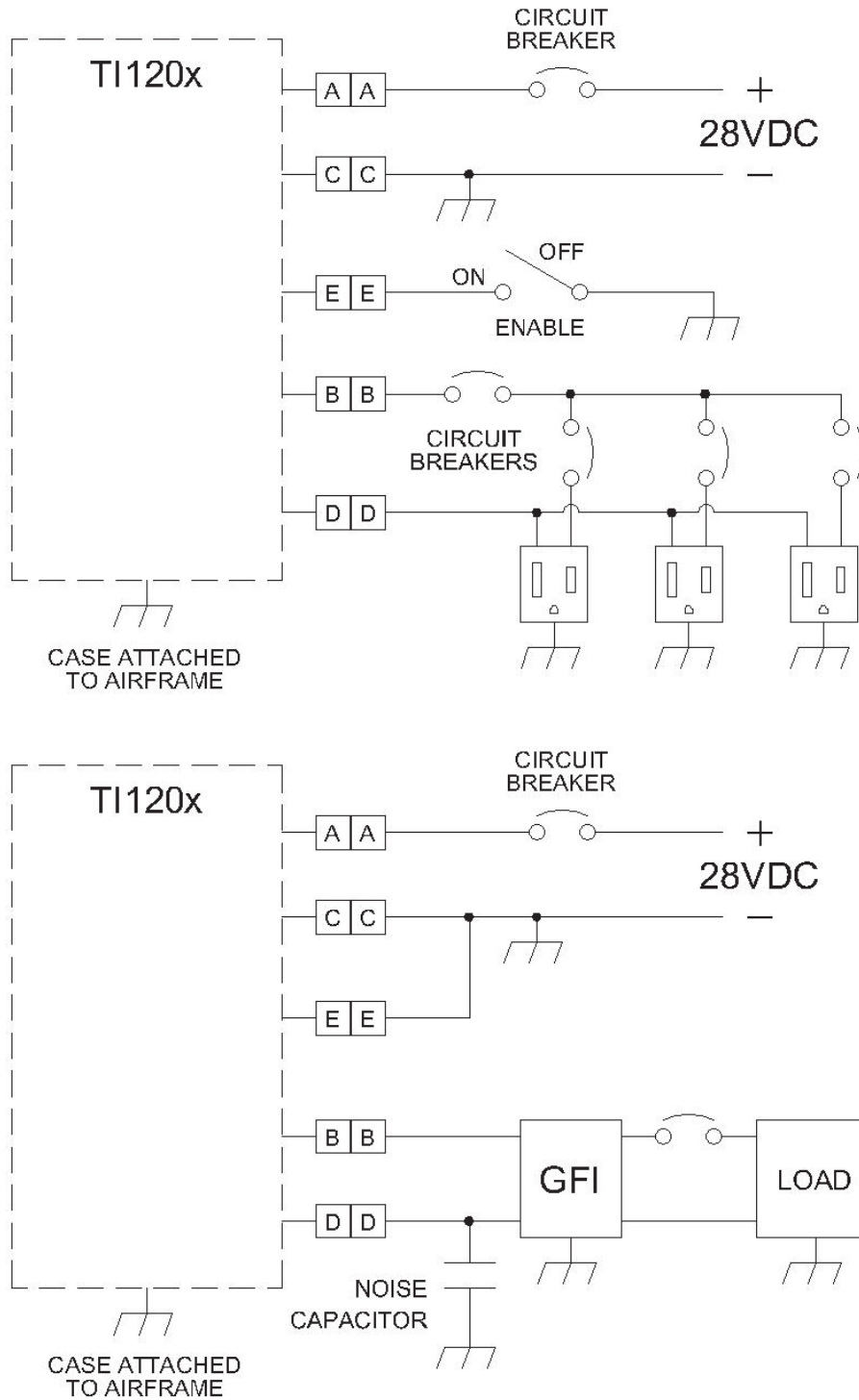

Figure 3.4
Example Wiring Diagrams

The wiring diagrams of Figure 3.4 provides general examples of typical installations. The configuration of individual aircraft installations may vary. Refer to Section 3 of this manual for circuit breaker rating(s), recommended wire sizes, and other details as these vary with the different model inverter output voltage and power ratings.

2.3.4 Harness Verification

With the TI1200 Series Static Inverter disconnected, activate the aircraft power bus that supplies the unit and use a multi-meter to verify that aircraft power and ground with appropriate voltage is on the pins within the mating harness.

2.4 MOUNTING

Refer to Section 2: Pre-Installation Considerations in regards to equipment location.

The TI1200 Series Static Inverter is designed for base mounting only. Four ¼-20 mounting holes should be provided in the aircraft in accordance with Figure 3.5. Secure the unit with four ¼-20 pan head Phillips screws, or equivalent. A lock-washer under the head of each screw is recommended.

2.5 INSTALLATION CAUTIONS

The TI1200 is not protected against reverse polarity on the input 28VDC. Verify the voltage polarity on the connector before connecting to the TI1200 for the first time.

The TI1200 inverter does not have the ability to phase sync the output to other AC power sources. Do not connect the output of the TI1200 to any other inverter or AC source or damage to the TI1200 will result.

NOTE – Digital meters measure AC voltage with a very high impedance. As noted in section 3.3.3, the TI1200 has a balanced AC output that is not referenced to the chassis. If a digital meter is used to measure the AC output to chassis, the reading will correspond to approximately ½ the inverter rated output voltage. This reading may vary depending upon the presence of an optional noise capacitor (section 3.3.3), permanently wired accessories, or presence of an external GFI. However, this voltage is not a problem and is a result of using a high-impedance meter to measure AC voltages.

2.6 INSTALLATION COMPLETION

Prior to operating the unit in the aircraft, it is recommended to verify the output and functionality of the unit. In order to prevent accidental damage to other systems, it is best not attach the output to other equipment or power busses prior to verification.

Verify the output of the unit at the terminating end of the cable with a multi-meter to ensure proper voltage and polarity. Once verified, installation can be completed and functionality of the remote on/off feature (if used) should be checked.

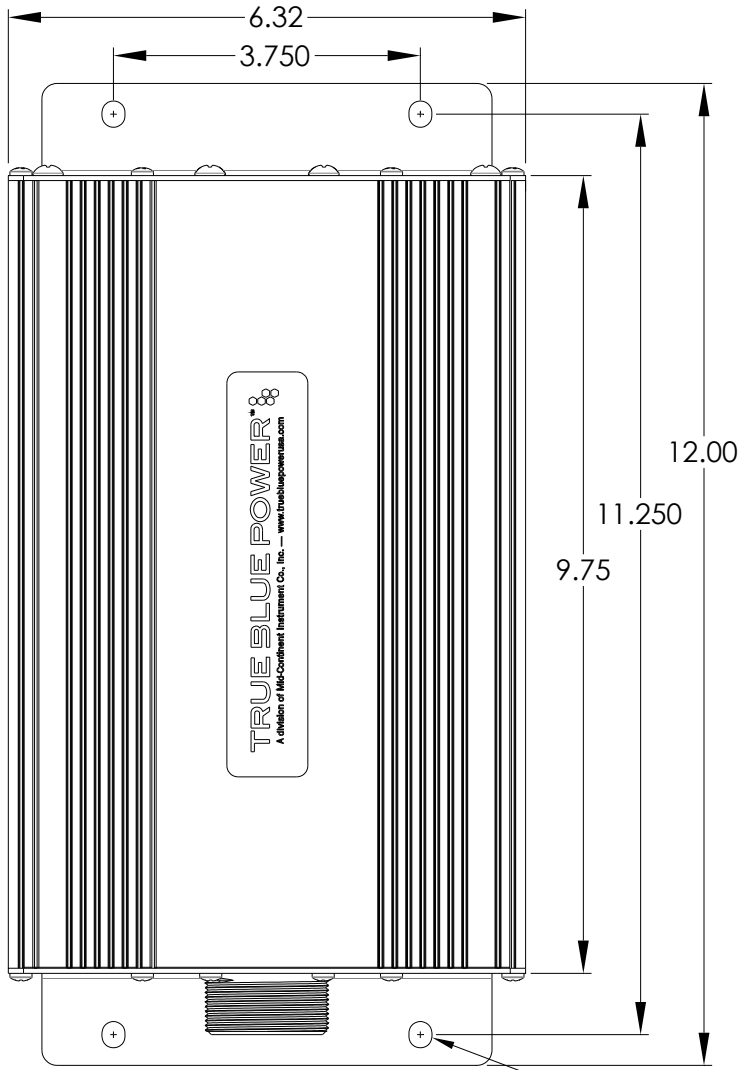

(4x) Ø 0.281
1/4-20 Mounting
Holes

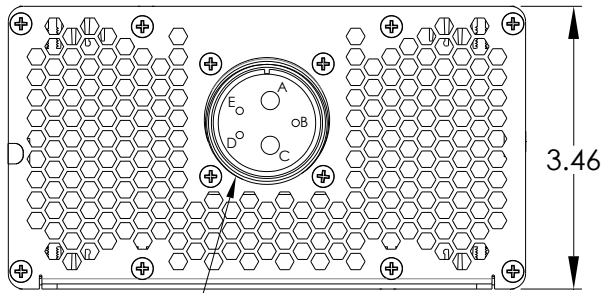

Connector per
MS3102A24-12P

Fan Air Exhaust at connector End

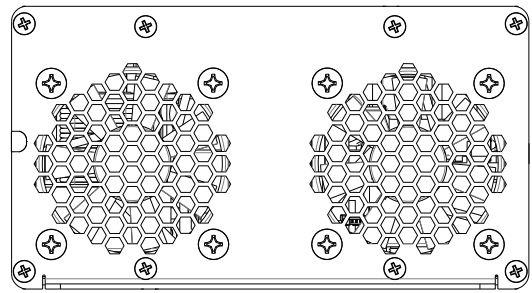

Fan Air Intake at this end of Inverter

Figure 3.5
TI1200 Series Outline Drawing

SECTION 3 OPERATION

3.1 ELECTRICAL PERFORMANCE

The TI1200 Series Static Inverter converts a direct current (DC) voltage input to a regulated, pure sine wave alternating current (VAC) output. Different models provide for outputs of 115 VAC 60 or 400 Hz, and 230 VAC 50 Hz. The unit is capable of providing 1200 watts to power a variety of aircraft accessories including laptops, personal electronics, onboard systems, and many others. For aircraft or helicopters where less electrical system current is available, a 230VAC 600 VA model of the TI1200 is available. (See Table 1.2 for tolerance ranges)

The unit is designed as a two-stage, solid-state switch-mode power supply. The power transformation utilizes a first-stage push-pull methodology followed by an H-bridge AC forming second stage. The primary stage utilizes 'current-mode' control providing instantaneous load protection as an advantage over legacy designs that incorporate 'voltage-mode' controllers. The alternating current is frequency controlled using a crystal oscillator reference.

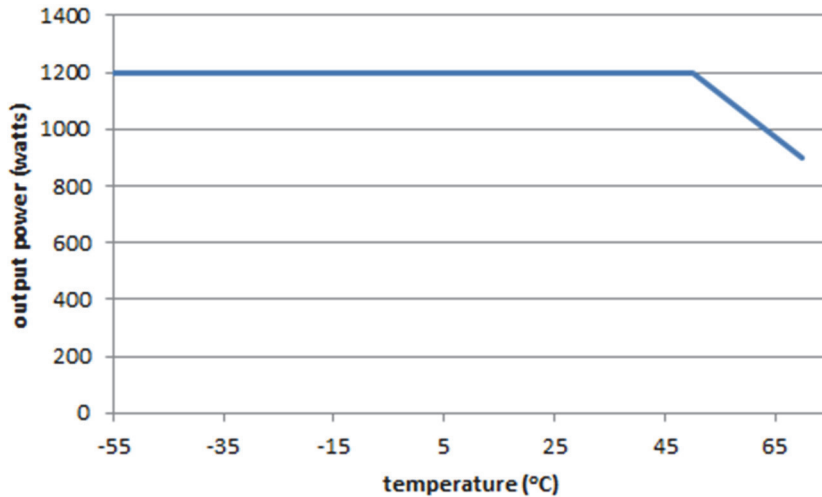

Figure 4.1

Output Power Performance vs Temperature

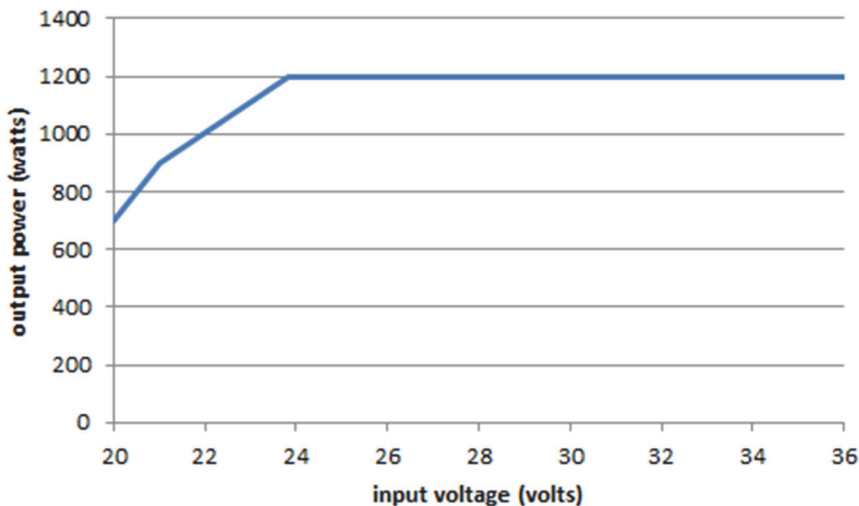

Figure 4.2

Output Power Performance vs Input Voltage

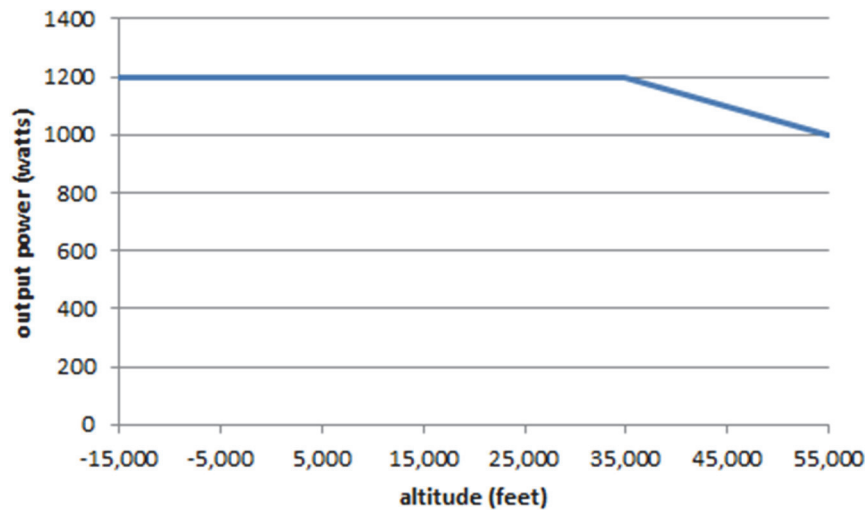

Figure 4.3
Output Power Performance vs Altitude

3.2 PROTECTIVE FEATURES

3.2.1 Remote On/Off

The TI1200 Series Static Inverter incorporates a remote on/off feature that allows the user to enable or disable the output of the unit. By providing a ground on the appropriate pin (See Table 3.3) the user, via a remote mounted switch or similar method, can enable the output of the unit. The unit can be similarly disabled by removing the ground signal (open circuit) to the same pin.

3.2.2 Over-Voltage

When the input voltage exceeds the operating range of the unit (See Table 1.2; absolute maximum input of 37VDC) the unit senses an over-voltage condition and disables the output. The unit will dynamically monitor the input voltage such that if the input returns to within the normal operating range, the output will be enabled and allow the unit to operate normally.

3.2.3 Under-Voltage

When the input voltage drops below the operating range of the unit (See Table 1.2; absolute minimum input of 20VDC) the unit senses an under-voltage condition and disables the output. The unit will monitor the input voltage such that if the input returns to within the normal operating range, the output will be enabled and allow the unit to operate normally.

3.2.4 Over-Temperature

The TI1200 Series incorporates an internal temperature sensing device that provides monitoring and feedback to the control circuits. When the unit senses an internal condition that exceeds maximum temperature, the inverter output is disabled and the internal cooling fans will continue to operate. The unit output will be enabled when the temperature returns to within acceptable limits. This over-temperature reset occurs automatically without any external intervention required.

3.2.5 Short Circuit and Over-Current for the 6431200-1, -2, -3, -5, and -6

The TI1200 Series is capable of surviving a short circuit or over-current event without permanent damage or effect to long-term reliability. The unit can provide over its rated power output up to 110% of rating or 1320 VA continuously (660VA for the 6431200-5). The power output is limited by temperature, input voltage and altitude as shown in Figures 4.1, 4.2, and 4.3. The unit monitors on pulse-by-pulse scenario to determine a short circuit or over-current situation.

If the load exceeds approximately 120% to 130% of rating or 1450VA to 1550 VA (approximately 720 VA for the 6431200-5), the output will limit by clipping the peaks of AC sine wave, limiting the power output.

At loads higher than approximately 1500VA, the inverter will not only clip the peaks of the AC sine wave output, but will begin to cycle the AC output ON and OFF at a 5 to 7 second rate further limiting the output power. Loads connected to the inverter output which use a power-ON momentary pushbutton feature will automatically turn-off when inverter output turns-off which should automatically remove some of the load on the AC circuit. When the inverter output cycles back to ON a few seconds later, the reduced load may allow the inverter to automatically return to continuous normal output.

At a full short circuit, the inverter will only draw around 10 amps from the 28V input, and will cycle ON and OFF at a 5 to 7 second rate continuously.

Once the overload or short circuit condition is removed, the AC output will return to normal operation within 7 seconds.

3.2.6 Over-Current and Installation for the 6431200-4

The typical T11200 series provides for an instantaneous peak-power output of greater than 1800 VA. However devices such as microwave ovens using an internal high-voltage transformer with rectified output to a magnetron, or electronic coffee makers that control heating by AC phase-modulating the heating element may be rated for an average of only 1200VA, but may exhibit an instantaneous peak power of 2200VA. For these applications, the 6431200-4 inverter is specially intended to meet the requirements of high peak-power AC loads with high crest power-factor or AC phase-modulated power requirements.

At loads exceeding the overcurrent setting of the 6431200-4, the inverter will clip the peaks of the AC sine wave output. At higher levels than this the AC output will cycle ON and OFF at a 5 to 7 second rate limiting output power. At a full short circuit, the inverter will only draw around 10 amps from the 28V input, and will cycle ON and OFF at a 5 to 7 second rate continuously.

Once the overload or short circuit condition is removed, the AC output will return to normal operation within 7 seconds.

Because the overcurrent operation of the 6431200-4 is set much higher, this model of inverter should be direct wired to the load, or have a dedicated outlet to the item being powered. The output of the inverter should not be available for general cabin use or inadvertent overloading of the inverter could occur damaging the inverter.

3.2.7 Temperature Regulated Cooling

The unit is equipped with two internal brushless DC fans for cooling to extend the power range and long-term life. The fans are activated at a specified point determined by the continuous monitoring of the internal temperature. The fans operate very quietly to reduce the audible noise in any environment. The two fans provide independent redundancy for protection of the unit in the event that one becomes inoperative.

SECTION 4 CONFORMANCE

4.1 CONTINUED AIRWORTHINESS STATEMENT

No periodic scheduled maintenance or calibration is necessary for continued airworthiness of the T11200 Series Static Inverter. If the unit fails to perform to specifications, the unit must be removed and serviced by Mid-Continent Instruments and Avionics or their authorized designee.

4.2 ENVIRONMENTAL QUALIFICATION STATEMENT

NOMENCLATURE: Static Electrical Power Inverter

MODEL NUMBER: T11200, T11202, T11204 **TSO NUMBER:** C73

MANUFACTURERS SPECIFICATIONS:

Minimum Performance Specifications: Test Specification (TS) 501, Test Data Sheet (TDS) 501

QUALIFICATION STANDARD: RTCA DO-160G

CONDITIONS	SECTION	DESCRIPTION OF TEST
Temperature and Altitude	4	Category F3(Y)
Low Temperature	4.5.1	Operating Low Temp = -55C
High Temperature	4.5.2	Operating High Temp = +70C
In-Flight Loss of Cooling	4.5.5	Category Y = 300 minutes, +40C, 75%
Decompression	4.6.2	Altitude = +55,000 ft
Overpressure	4.6.3	-15,000 ft
Temperature Variation	5	Category S2
Humidity	6	Category B
Operational Shock and Crash Safety	7	Category B
Vibration	8	Category R, Curve C, C1 Category U, Curve G [(RCC1)(UG)]
Explosion	9	Category X
Waterproofness	10	Category X
Fluids	11	Category X
Sand and Dust	12	Category X
Fungus	13	Category X
Salt Spray	14	Category X
Magnetic Effect	15	Category Z
Power Input	16	Category X
Voltage Spike	17	Category X
Audio Frequency Conducted Susceptibility	18	Category X
Induced Signal Susceptibility	19	Category X
Radio Frequency Susceptibility	20	Category X
Emission of Radio Freq Energy	21	Category B
Lightning Induced Transient Susceptibility	22	Category X
Lightning Direct Effects	23	Category X
Icing	24	Category X
ESD	25	Category X
Flammability	26	Category X