

Table of Contents

1	Installation Instructions	2
2	Placards and Markings	2
3	Installing the Fuel Flow Transducer:	3
4	Mounting Procedure 700921	4
5	Mounting Procedure: 700922	5
6	Mounting Procedure 700923	6
7	Mounting Procedure:700924	7
8	Specifications and Limitations	8
9	TSO Conditions	8
10	Specifications and Limitations	9
11	TSO Label	10
12	Operating Instructions	11
13	Initial Check Out	12
14	List of Major components:	14
15	Instructions for Continued Airworthiness (ICA)	14
16	Wiring Drawing	15
17	Template Drawing	16

J.P.INSTRUMENTS
PO BOX 7033
HUNTINGTON BEACH CA 92646

1 Installation Instructions

General: A complete thorough familiarization and understanding of the system and this manual is necessary before commencing the installation. All work must conform with A.C. 43.13.1A ch. 11 sec. 2, 3, 7. The accuracy of this instrument depends entirely upon the accuracy of the data entered. A periodical checking of the actual fuel onboard will eliminate the accumulation of errors due to evaporation leaks, etc.

Route the (Optional) External Warning Control Line: The wire from pin 4 on the J-1 (D-SUB 9) can be connected to an external warning light or buzzer. This pin goes to ground when the display flashes a warning. The current in this line must be limited to 0.25 amps (maximum). Exceeding this limit will damage the unit. Tie off this wire if not in use as not too obstruct the freedom of the controls. The FS-450 can be connected in parallel to any existing digital fuel flow system. When connected to an existing flow sensor pin 3 red is not connected. See drawing 450508.

Install the Instrument in the Panel: Locate a 2.25 diameter hole or 3.125 diameter in the instrument panel, where you would like to mount the indicator per drawing 450124. The instrument **configures itself automatically** for 14/28 volt aircraft. The instrument is 1.5" deep less connectors and is 2.6 or 3.5 square behind the panel.

Route the Fuel Flow Transducer Wires: Route the fuel flow wires from the probes through the firewall using fireproof rubber grommets and flame retarding silicone. Use an existing hole if possible. Following the existing wiring harness. All wires must be routed **away from high temperature** areas (exhaust stacks, turbochargers, etc.). Secure Probe leads to a convenient location on the engine, being sure there is sufficient slack to absorb engine torque. It is essential in routing the fuel flow transducer wires not be allowed to touch metal parts of the air-frame or engine since abrasion will destroy this wire. Connect wires in accordance with DWG 450508.

2 Placards and Markings

Do not use the PN 700900-1 Flow Transducer on aircraft with a gravity feed system.

Transducer Identification Markings

PN 700900-1 stamped on TSO label and Marked "201" on the top of the unit,

PN 700900-2 stamped on TSO label and Marked "231" on the top of the unit.

PN FT4-8AEXS-LEA-2029 stamped on transducer side

The placard PN 700905

"Do Not Rely on Fuel Flow Instrument to Determine Fuel Levels in Tanks."

Must be mounted on the aircraft instrument panel near the P/N 450000().

If the aircraft is equipped with a primary fuel flow gage, the following placard must be mounted on the aircraft instrument panel near the P/N 450000().

"Refer to Original Fuel Flow Instrumentation for Primary Information."

Aircraft Configuration	Drawing	Location
1. PN 450000-G All gravity Flow installations without fuel pump. Must use transducer PN 700900-2	700923	Between Fuel tank and Carburetor.
2. PN 450000-P All Fuel injected engines with vapor return lines to fuel tank , all Continental and certain Lycoming engines.	700922	Between throttle body and fuel flow divider.
3. PN 450000-P,-H All pump fed carbureted and Fuel injected engines without vapor return lines. PN 450000-P range up to 60 GPH and PN 450000-H range up to 120 GPH	700921	Between engine driven pump and servo/throttle body or carburetor
4. PN 450000-D Pressure Carbureted engines with vapor return lines. Requires Dual transducers	700924 450508	One transducer in Carb inlet line and one transducer in outlet line
5. PN 450000-M- If "M" is after the PN it signifies that the display is 3" Fuel flow for twin engine aircraft single indicator.	700922	Between throttle body and fuel flow divider.

3 Installing the Fuel Flow Transducer:

Mount the Fuel Flow Transducer using the appropriate drawing in this manual.

The instructions listed below must be followed when installing a Fuel Flow Transducer.

Note: If your engine is equipped with a fuel return line from the carburetor back to the fuel tank two transducers are required.

The transducer output port should be mounted lower or even with the carburetor inlet port (or fuel servo on a fuel injected engine). If this is not possible, a loop should be put in the fuel line between the Fuel Flow Transducer and the carburetor or fuel servo (see diagram below). It is recommended **not to hard mount** the transducer to the carburetor or fuel servo.

Do not remove the caps on the flow transducer until the fuel hoses are ready to be installed.
 The flow of fuel through the transducer must follow the direction marked on the transducer.

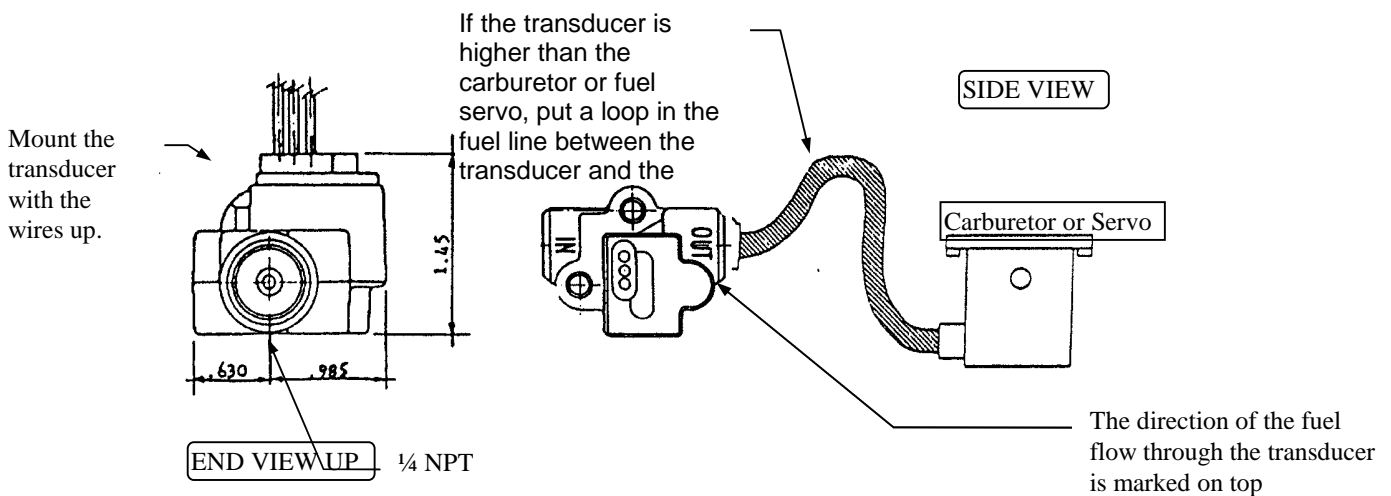

The flow transducer must be mounted so the wires exiting the transducer are pointing up.
 Before connecting any hoses, thoroughly clean them and insure they are free of any loose material. High air pressure may be used, **However, do not allow high air pressure to pass through the flow transducer.**

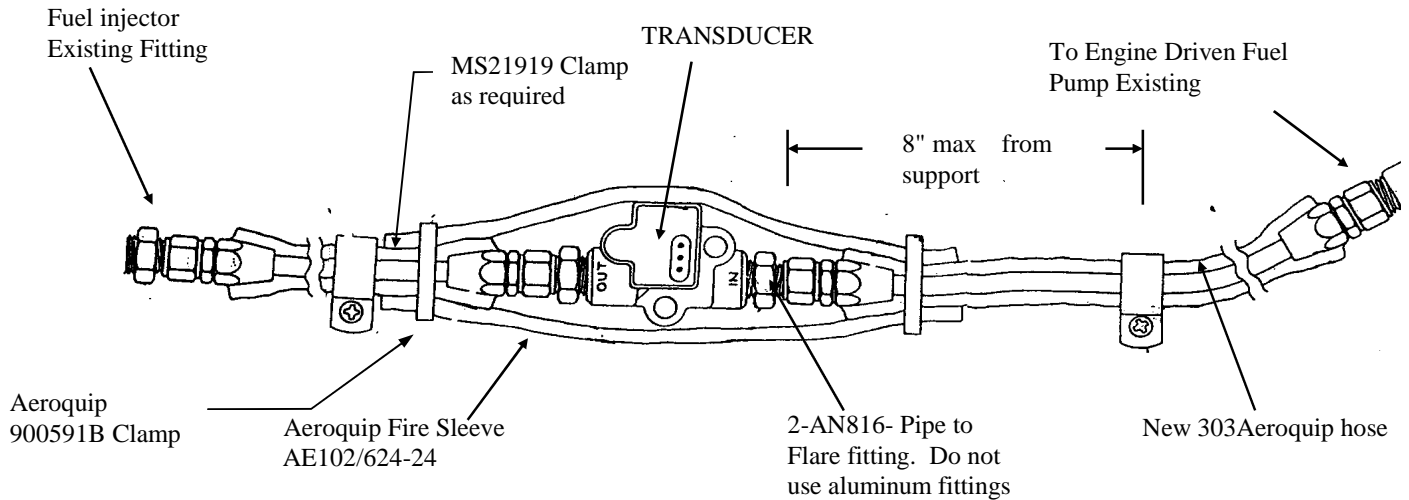

4 Mounting Procedure 700921

1. Find a convenient location within 8" of a hose support or fitting and away from any hot exhaust pipes to suspend the Fuel Flow Transducer. The hose support or fitting may be on the input or output line of the Flow Transducer.
2. Remove the fuel hose which goes from the Fuel Pump to the Carburetor (or Fuel Servo).
3. Purchase two new hoses, one from the fuel pump (or the Fuel Filter) to the Fuel Flow Transducer and the other from the Fuel Flow Transducer to the carburetor (or fuel servo). **There must be flexible hose in and out of the Transducer.** The hoses must meet TSO-C53a Type C or D FAA specification. **The new hoses must be the same size as the current hose in the aircraft.**
4. Before connecting fuel hose to the carburetor, verify that the boost pump delivers at least 125% of takeoff fuel consumption at minimum fuel pressure as marked on fuel pressure gage.
5. Mount the Fuel Flow Transducer in the fuel line. **The Flow Transducer must be wrapped with Fire Sleeving available at JPI.** Place a small hole in the fire sleeve and pass the transducer wires through it. Seal with High temperature Silicone RTV sealant
6. For best results it is advisable to have two inches of straight tube just before the inlet to the transducer

J.P.INSTRUMENTS			
PO Box 7033			
Huntington Beach CA 92646			
Title : Installation of a Fuel Flow Transducer in the fuel line from the fuel pump to the carburetor or fuel servo.			
Drawing No. 700921			
Date	Drawn	Approved	Rev NC
02/14/97			

5 Mounting Procedure: 700922

1. Find a convenient location between the Throttle Body and the Flow Divider and away from any hot exhaust pipes to suspend the Fuel Flow Transducer.
2. Remove the fuel hose which goes from the Throttle Body to the Flow Divider.
3. Purchase two new hoses, one from the Fuel Servo to the Fuel Flow Transducer and the other from the Fuel Flow Transducer to the Flow Divider. **There must be flexible hose in and out of the Fuel Transducer.** The hoses must meet TSO-C53a Type C or D FAA specification. The new hoses **must be the same size as the current hose in the aircraft.**
4. Mount the Fuel Flow Transducer in the fuel line. **The Flow Transducer must be wrapped with Fire Sleeve available at JPI.** Place a small hole in the fire sleeve and pass the transducer wires through it. Seal with High temperature Silicone RTV sealant.
5. Secure at either end of the transducer to any convenient point on the engine with MS21919 clamps or equivalent.
6. For Continental fuel injected engines adjust the fuel pressure to account for the pressure drop across the transducer per **Continental Service Bulletin M89-10, available at JPI.**

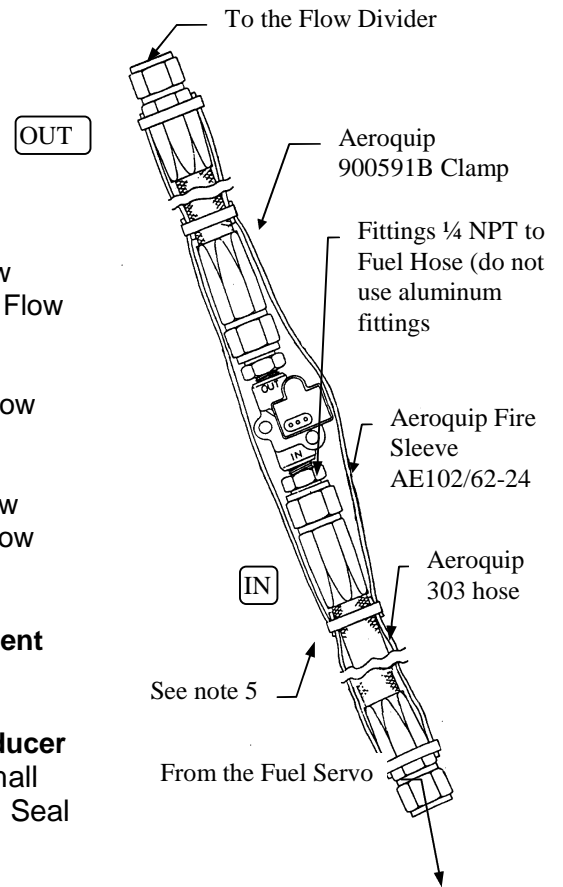

J.P.INSTRUMENTS			
PO Box 7033 Huntington Beach CA 92646			
Title Installation of the Fuel Flow Transducer in the fuel line between the Throttle Body and the Flow Divider. Only applicable for Continental Fuel Injected Engines			
Drawing No. 700922			
Date 02/14/97	Drawn/	Approved 	Rev NC

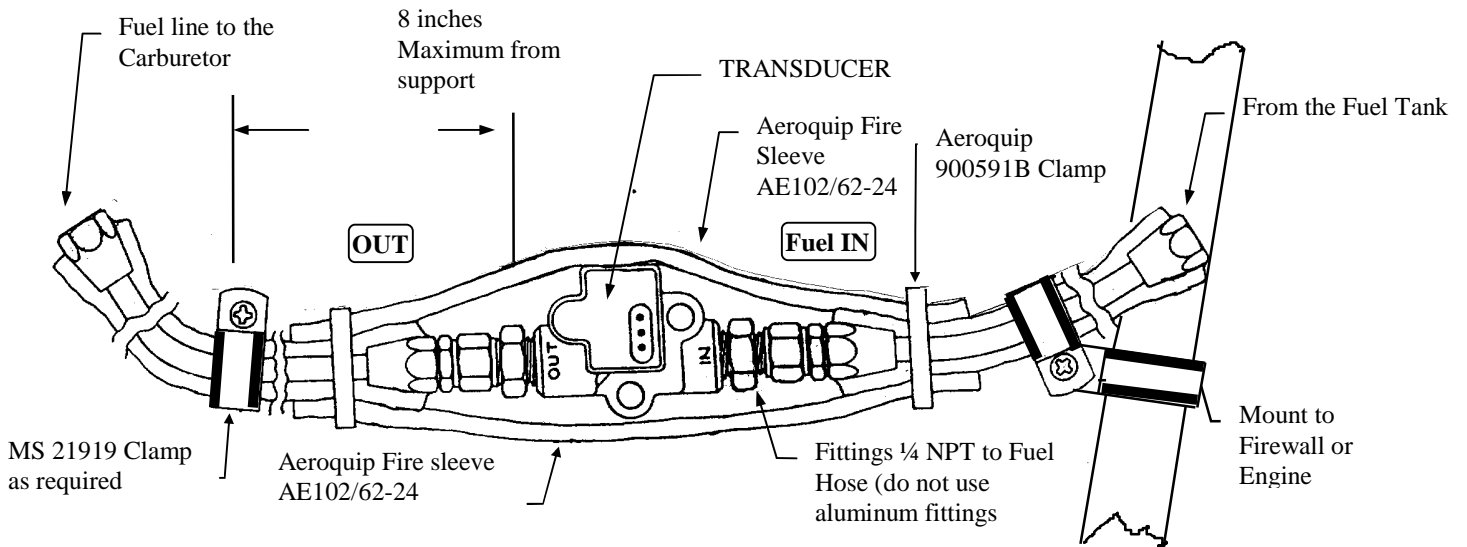

6 Mounting Procedure 700923

1. Find a convenient location within 8" of a hose support or fitting and away from **any** hot exhaust pipes to suspend the Fuel Flow Transducer. The hose support or fitting may be on the input or output line of the Flow Transducer.
2. Remove the fuel hose which goes from the Carburetor to the Fuel Tank.
3. Mount the Fuel Flow Transducer in the fuel line. **You must use the 700900-2 Fuel Flow Transducer on a gravity feed system.** The PN 700900-2 Transducer is marked "Model 231" on the top of the transducer. **The Flow Transducer must be wrapped with Fire Sleaving available at JPI.** Place a small hole in the fire sleeve and pass the transducer wires through it. Seal with High temperature Silicone RTV sealant.
4. Purchase two new hoses, one from the Fuel tank to the Fuel Flow Transducer and the other from the Fuel Flow Transducer to the Carburetor. **There must be flexible hose in and out of the Fuel Transducer.** The hoses must meet TSO-C53a Type C or D FAA specification. The new hoses **must be the same size as the current hose in the aircraft.**
5. For best results it is advisable to have two inches of straight tube just before the inlet to the transducer.

J.P.INSTRUMENTS			
PO Box 7033			
Huntington Beach CA 92646			
Title : Gravity Installation of a Fuel Flow Transducer in the fuel supply line from the fuel tank to the carburetor without a fuel pump.			
Drawing No. 700923			
Date 02/14/97	Drawn/ 02/14/97	Approved 	Rev NC

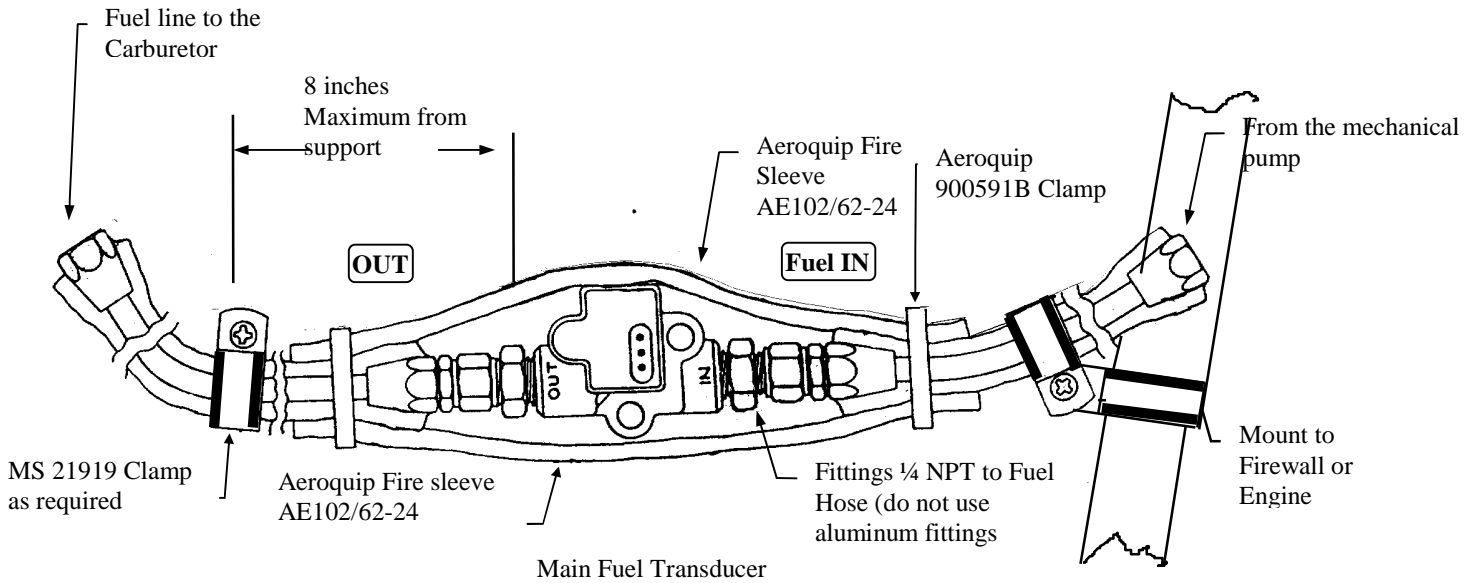

7 Mounting Procedure:700924

1. Find a convenient location within 8" of a hose support or fitting and away from **any** hot exhaust pipes to suspend the Fuel Flow Transducer. The hose support or fitting may be on the input or output line of the Flow Transducer.
2. Remove the fuel hose which goes from the mechanical pump to the Carburetor.
3. Remove the fuel hose which goes from the Carburetor return line to the Fuel Tank.
4. Mount the Fuel Flow Transducer in the fuel line from the mechanical pump to the Carburetor per the above drawing; note the flow direction on the transducer. Mount the return Fuel flow transducer in the return line from the Carburetor to the fuel tank, note the transducer will be reversed. This kit is supplied with two PN 700900-1 transducers. Check the K factors to be within 0.1. Either transducer may be used as the supply transducer. **Both Flow Transducers must be wrapped with Fire Sleaving available at JPI.** Place a small hole in the fire sleeve and pass the transducer wires through it. Seal with High temperature Silicone RTV sealant.
5. **There must be flexible hose in and out of the Fuel Transducer.** The hoses must meet TSO-C53a Type C or D FAA specification. The new hoses **must be the same size as the current hose in the aircraft.**
6. Before connecting fuel hose to the carburetor, verify that the boost pump delivers at least **125%** of takeoff fuel consumption at minimum fuel pressure as marked on fuel pressure gage.

J.P.INSTRUMENTS

PO Box 7033

Huntington Beach CA 92646

Title : Differential Installation, of a Fuel Flow Transducer in the fuel supply or return line from the carburetor to the fuel tank

Drawing No. 700924

Date
02/14/97

Drawn/
02/14/97

Approved 

Rev NC

8 Specifications and Limitations

Model:

FS-450, PN 450000()

Case Dimensions:

2.6" x 2.6" x 1.5" depth, 2 1/4" round Bezel.
3.26" x 3.26" x 1.56" depth, 3.12 round Bezel

Weight:

Unit Only	0.08 lbs
Indicator & Harness:	0.25 Lbs.
Flow Transducer: PN 700900-1,-2	0.19 Lbs.
Hi flow PN FT4-8AEXS-LEA-2029	0.5 Lbs.

Power Requirements:

10 to 35 Volts, 0.2 Amp. 1 amp CB

Low Fuel Warning Display

The display message will blink anytime the programmed, Low Fuel Warning or the Time to Empty Limit are violated.

External Warning Control Line:

Takes wire on pin 4 to ground when blinking. Current should be limited to 0.25 amp.

Accuracy:

Flow: 2% or better in accordance with TSO C44b.

Resolution

Fuel Flow:	0.1 Gal. or 1 Lb. or 1 Lt.
Fuel Remaining:	0.1 Gal. or 1 Lb. or 1 Lt.
Fuel Used:	0.1 Gal. or 1 Lb. or 1 Lt.
Time to Empty:	10 minute default

Max Displayed Range (Unit Only):

Fuel Flow:	199.9 Gals. or 162.0 or Gal/Hr or 1199 Lbs./Hr or 749 Ltr./Hr.
Fuel Remaining:	999 Gals. or 811 or Gals. or 1999 Lbs. or 1999 Ltrs.
Fuel Used:	999 Gals. or 811 or Gals. or 1999 Lbs. or 1999 Ltrs.
Time to Empty:	19 hours 59 minutes

9 TSO Conditions

"The conditions and test required for TSO approval of this article are minimum performance standards. It is the responsibility of those desiring to install this article either on or within a specific type or class of aircraft to determine that the aircraft installation conditions are within the TSO standards. The article may be installed only if installation of the article is approved by the Administrator."

10 Specifications and Limitations

Instrument P/N 450000-P, -D Transducer P/N, 700900-1	Instrument P/N 450000-G Transducer P/N 700900-2
Range: 0.6 to 60 GPH	Range: 3 to 90 GPH
Linearity: %1 (8 to 60 GPH)	Linearity: %1 (8 to 60 GPH)
K Factor: Approx. 29,000	K Factor: Approx. 19500
Pressure Drop: 1.2 PSI at 30 GPH 4.8 PSI at 60 GPH	Pressure Drop: .31 PSI at 30 GPH 2.8 PSI at 90 GPH
Working Press: 200 PSI	Working Press: 200 PSI
Min. Burst Press: 2000 PSI	Min. Burst Press: 2000 PSI
Operating Temp. Range -55 °C to 70 °C	Operating Temp. Range -55 °C to 70 °C
Non Operating Temp. Range: -65 °C to 100 °C	Non Operating Temp. Range: -65 °C to 100 °C
Fuel Ports: 1/4" Female NPT	Fuel Ports: 1/4" Female NPT

Instrument P/N 450000-H . Transducer P/N (FT 4-8AEXS-LEA-2029)
Range: 3 to 120 GPH
Linearity: %1 (9 to 120 GPH)
K Factor: Approx. 48,000
Pressure Drop: 0.23 PSI at 30 GPH 0.8 PSI at 60 GPH
Working Press: 1500 PSI
Min. Burst Press: 2000 PSI
Operating Temp. Range -55 °C to 70 °C
Non Operating Temp. Range: -65 °C to 100 °C
Fuel Ports: AN816-8-8

RS232/422 Input Ports FS-450 .	
Single Line Receive Method:	RS-232C, RS-423, or 5 Volt Serial.
Protocol:	1 Start bit, 8 Data bits, 1 Stop bit.
Baud Rate:	Automatic: 9600,4800,1200
Format:	Automatic: Aviation Date, Northstar Binary, NMEA-183

RS232 Output Port	
Transmit Method:	RS-232 Single Line.
Protocol:	1 Start bit, 8 Data bits, 1 Stop bit.
Baud Rate:	9600
Transmit Format:	Garmin, Allied Signal, Arnav, UPS

11 TSO Label

REV	DESCRIPTION	DATE	BY
NC	PRODUCTION RELEASE	11/00	JP
A	REDRAWN ADDED BOX M	3/02	JFP

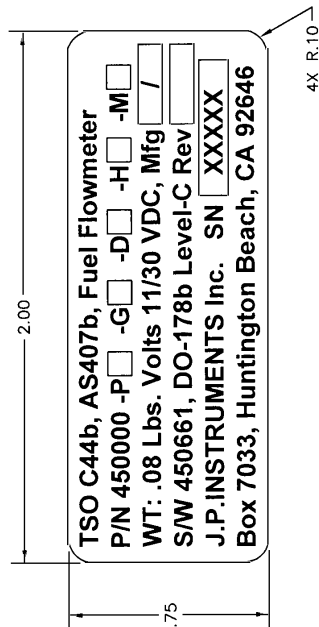

TSO C44b, AS407b, Fuel Flowmeter
P/N 450000 -P [] -G [] -D [] -H [] -M []
WT: .08 Lbs. Volts 11/30 VDC, Mfg [] / []
S/W 450661, DO-178b Level-C Rev []
J.P.INSTRUMENTS Inc. SN [] XXXXX
Box 7033, Huntington Beach, CA 92646

ACTUAL SIZE

NOTES UNLESS OTHERWISE SPECIFIED:

1. MATERIAL: COMPUTER PRINTABLE POLYESTER OR EQUIVALENT
2. ADHESIVE: PERMANENT
3. COLORS: UV BLACK INK BACKGROUND WITH WHITE FONTS
BOXES HAVE WHITE BACKGROUND WITH BLACK UV INK FONTS
4. FONT: ARIAL, BOLD
5. FINISH: VARNISH UVF 08052 OR EQUIVALENT
WRITABLE WITH SHARPEE MARKER
RESISTANT TO WIPING WITH 70% ISOPROPYL ALCOHOL
6. FUNCTION: PERMANENT NAMEPLATE LABEL ON FLAT PLASTIC SURFACE

UNLESS OTHERWISE NOTED		DRWN
TOLERANCES		CHKD
.X ±.050	ANGULAR ±.5°	APPRD
.XX ±.020	THDS. CLASS 2	APPRD
.XXX ±.005	MACH. SURF. $\frac{\sqrt{2}}{2}$	SCALE
MACH. DIMS. CONCENTRIC WITHIN .005 T.I.R.	FINISH	MODEL
BREAK ALL SHARP EDGES .005 - .020	SEE NOTES	DWG. NO.
MACH. FILLET RADIUS .020 MAX	SEE NOTES	REV
MACH. SURF. FLAT WITHIN .001 IN./IN.	SEE NOTES	1450
OTHER SURF. FLAT WITHIN .005 IN./IN.	SEE NOTES	A
DO NOT SCALE DRAWING	TITLE	SHEET 1 OF 1
	LABEL, TSO-C44b, FS-450 FUEL FLOWMETER	

THIS DRAWING CONTAINS PROPRIETARY INFORMATION OF J.P. Instruments COPYRIGHT © 2002

12 Operating Instructions

The FS-450 Fuel Scan uses a small turbine transducer that measures the fuel flowing into the engine. Higher fuel flow causes the transducer turbine to rotate faster which generates a faster pulse rate. Prior to engine start you inform the FS-450 Fuel Scan of the known quantity of fuel aboard, and it will keep track of all fuel used. There are two standard operating modes of the FS-450: Automatic Scanning, and Manual Scanning. The FS-450 has programmable alarms. When the remaining amount of fuel falls below the alarm limit the bottom display will show the amount of fuel REMaining and the specific cue light will flash. When the remaining time falls below the alarm limit the bottom display will show the MINutes of fuel remaining and the specific cue light will flash. When an alarm is displayed, tapping the STEP button will temporarily disable the alarm indication for the next ten minutes. When an alarm is displayed, holding the STEP button until the word **OFF** appears will disable that alarm indication for the remainder of the flight. After initial self-test, you will be asked to inform the FS-450 of start up fuel. The FS-450 will display **FUEL GAL** (or **Ltr** liters or **Lbs** pounds) for one second, and then flash **FILL ? n** until any button is pressed. The display will pause at each parameter for a few seconds in the Automatic scanning mode. In the Manual scanning mode, tap the STEP button to advance to next parameter. Holding the STEP button will display the previous parameters in the sequence (rapidly backwards).

Procedure—Changing the Set Up by entering the program mode.

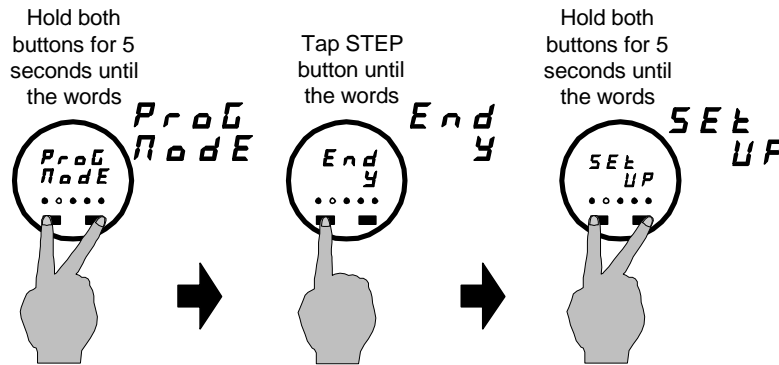

Tap STEP to next item	AUTO sequences through these values	Description
FUEL GAL	GAL ⇒ Ltr ⇒ Lbs ⇒	Selects fuel units
MAIN = 50	Hold or tap AUTO to select main capacity	Main tank capacity, in units selected
AUX ? n	n ⇔ y	Y—Yes—aircraft has auxiliary tanks (next step)
AUX = 0	Hold or tap AUTO to select AUX capacity	Auxiliary tank capacity (skipped if AUX? is no)
MIN = 45	Hold or tap AUTO to select low time limit	Alarm limit in minutes for low time in tanks
REN = 10	Hold or tap AUTO to select low quantity limit	Alarm limit for low fuel quantity in tanks, in units selected
Carb ? n	n ⇔ y	Y—Yes—carbureted engine
End y	n ⇔ y	Y—Yes to exit; N—No to review list again

- Digital display for numeric readouts and messages: top display is fuel flow and the lower display for all other parameters.
- Indicator lights to show what information is being displayed on the digital display

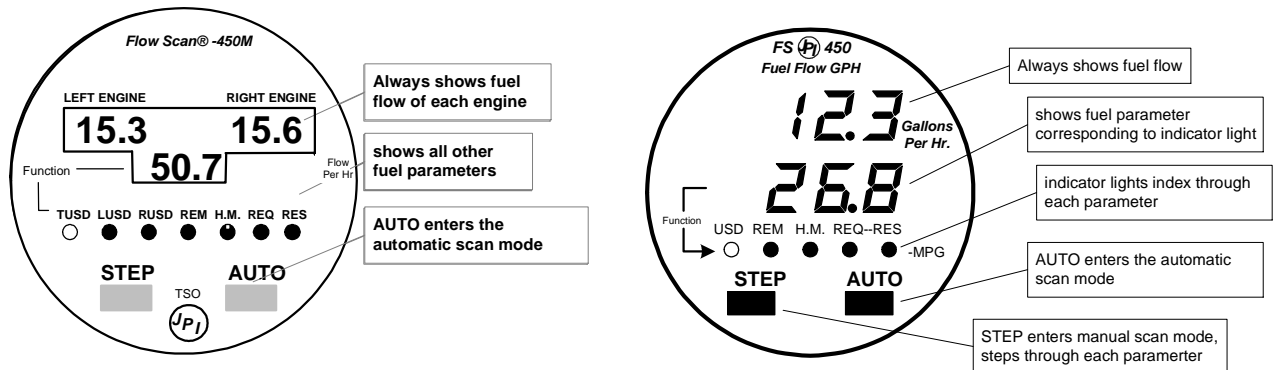

Parameter Description	Example	Comments
USD —Total Fuel Used	38 . 2	Since last refueling or trip total.
REM —Fuel Remaining	37 . 2	In gallons, liters or pounds
H.M. —Time to Empty	02 . 45	Hours. Minutes Remaining at current fuel burn
REQ —Fuel required to next GPS WPT or Destination	25 . 8	Present with GPS interface Valid signal and way point
RES —Fuel Reserve at next GPS WPT or Destination	I I . 3	Present with GPS interface Valid signal and way point

13 Initial Check Out

- **Electronics Warranty:** The aircraft owner must read the Warranty before starting the installation. There is information in the Warranty that may alter your decision to install this instrument. If you do **not accept the terms of the Warranty, JPI offers a 30 day money back guarantee.**
- **Transducer Warranty:** All transducers suspected of malfunctioning must be sent back to JPI to be bench flow tested. JPI sends the transducer back to the original manufacturer for testing, who in turn charges JPI, \$70 for the testing. If the transducer is found defective a new transducer will be issued.
- **If you are not an FAA Certified Aircraft Mechanic familiar with the issues of installing aircraft fuel flow, Do Not attempt to install this instrument.** The installer should use current aircraft standards and practices to install this instrument (refer to AC 43.13).
- Read the entire Installation Instructions and resolve any issues you may have before starting the installation.
- **THIS INSTALLATION WILL REQUIRE SOME PARTS UNIQUE TO YOUR AIRCRAFT THAT ARE NOT SUPPLIED IN THE KIT (including, but not limited to hoses and fittings).** Acquire all the parts necessary to install this instrument before starting the installation. **Do not use aluminum fittings** with the PN 700900-1 or PN 700900-2 transducer.

- Check that the instrument make and model are correct before starting the installation (check the markings on the side of the instrument). A gravity feed system requires an PN 700900-2 flow transducer (marked "231" on top). A carbureted engine with a fuel return line requires two transducers at additional cost
- If this instrument is to replace an existing unit in the aircraft, it is the installer's responsibility to move or replace any existing instruments or components in accordance with FAA approved methods and procedures. The following Installation Instructions do not cover moving or the removal of any existing instruments or components.
- Before connecting any hoses to the transducer, thoroughly clean them and insure they are free of any loose material. **Never pass high pressure air through or blow through the transducer, damage will occur.**
- Remove the transducer cap plugs when ready to install hoses. **Do not use aluminum fittings** with the fuel flow transducer or Gauling may occur.
- The inlet and outlet ports of the transducer have ¼ NPT threads. When assembling fittings into the inlet and outlet Do Not Exceed a torque of 15 ft. lbs. Or screw the fittings in more than 2 full turns past hand tight.
- A screen or filter should be installed upstream of the transducer. As turbulence upstream of the transducer affects it's performance, there should be a reasonable length of straight line between the transducer inlet.
- Install the transducer with the wires leads UP to vent bubbles and insure that the rotor is totally immersed in fluid.
- Note the direction of fuel flow marked on the transducer. Fuel must flow in this direction.
- Note and record the K-factor engraved in the side of the transducer and also on the white tag attached to the transducer. Most transducers have a K- factor of 29.90.

10. System Checkout: Check instrument operation as follows:

- Turn the aircraft master switch on (engine off). Tap the step switch until 0 GPH is displayed. Turn the boost pump on for a few seconds. The display should indicate 3 to 8 GPH.. A problem at this step could be caused by poor connections on the red or black power and ground leads.
- A reading of " --- " dashes indicate no fuel flow transducer signals. A problem at this step could be caused by a poor connection or crossed flow transducer wires.
- With the engine running, check the "FLOW" Display to read properly.
- **After running the engine, check the fuel hoses, transducers and fittings for leaks.**

14 List of Major components:

PN 450000-()	-P	-G	-D	-H	-M
Indicator PN 450000	1	1	1	1	
Indicator PN 450000-M					1
Harness PN 450507	1	1		1	
Harness PN 450510			1		
Harness PN 450506					1
Transducer PN 700900-1	1		2		2
Transducer PN 700900-2		1			
Transducer High Flow PN FT4-8AEXS-LEA-2029				1	

Part Number	Description
PN 450000-P	All pump fed Carburetor and injected engines with maximum take-off flow range to 60 GPH
PN 450000-G	All Gravity feed systems without mechanical pump
PN 450000-D	All pressure carburetor systems with return line to tank
PN 450000-H	All mechanical pump fed systems with a high flow range, on take-off, to 120 GPH.
PN 450000-M	Fuel flow for twin engine aircraft single indicator

15 Instructions for Continued Airworthiness (ICA)

There are no field adjustments and or calibration requirements for the P/N 450000 series instrument after initial installation. ICA is not required. Maintenance of nonfunctioning or malfunctioning components is limited to removal and replacement of JPI factory supplied new or repaired components as described in the troubleshooting section of the installation instructions

16 Wiring Drawing

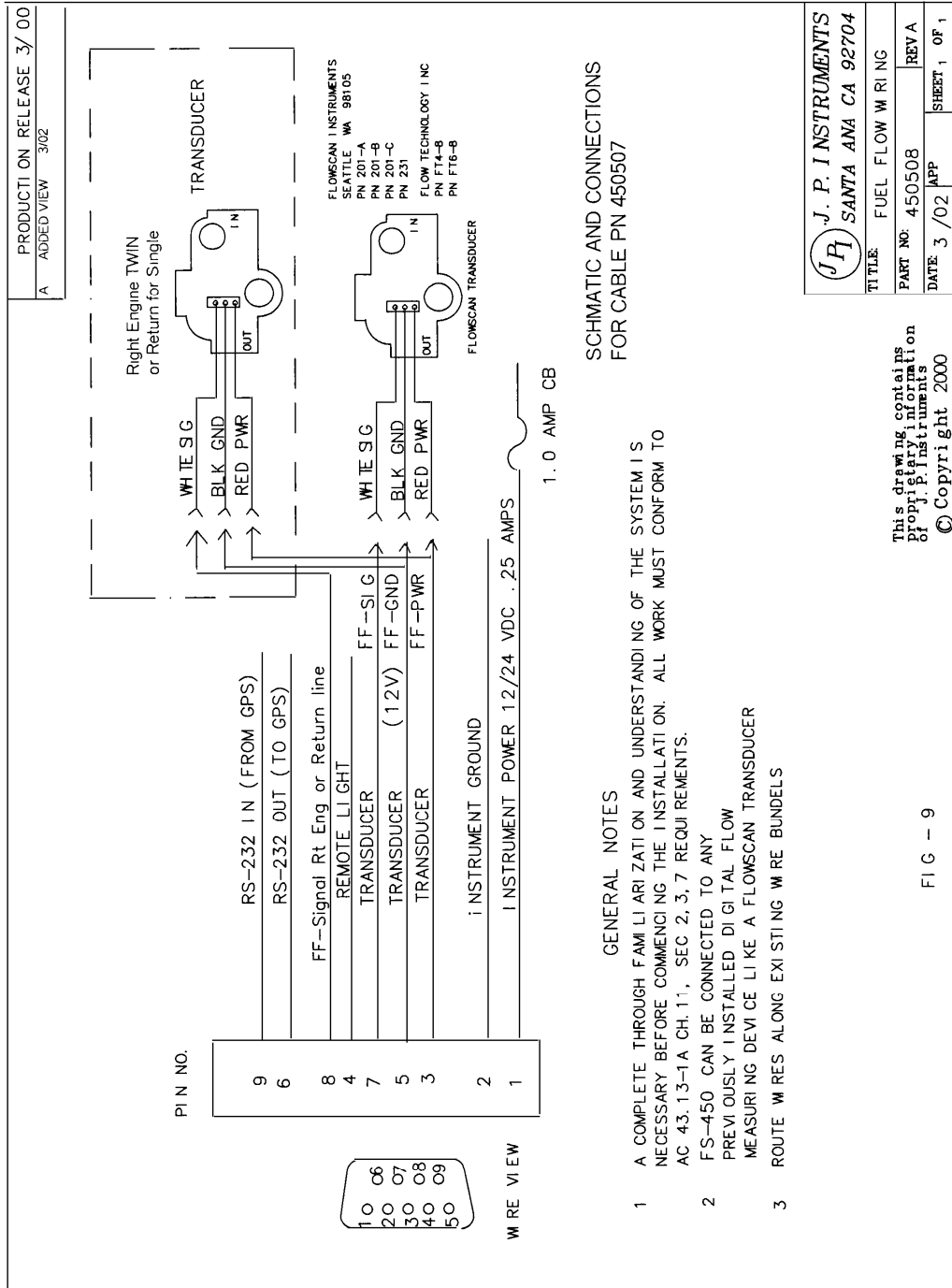

17 Template Drawing

