

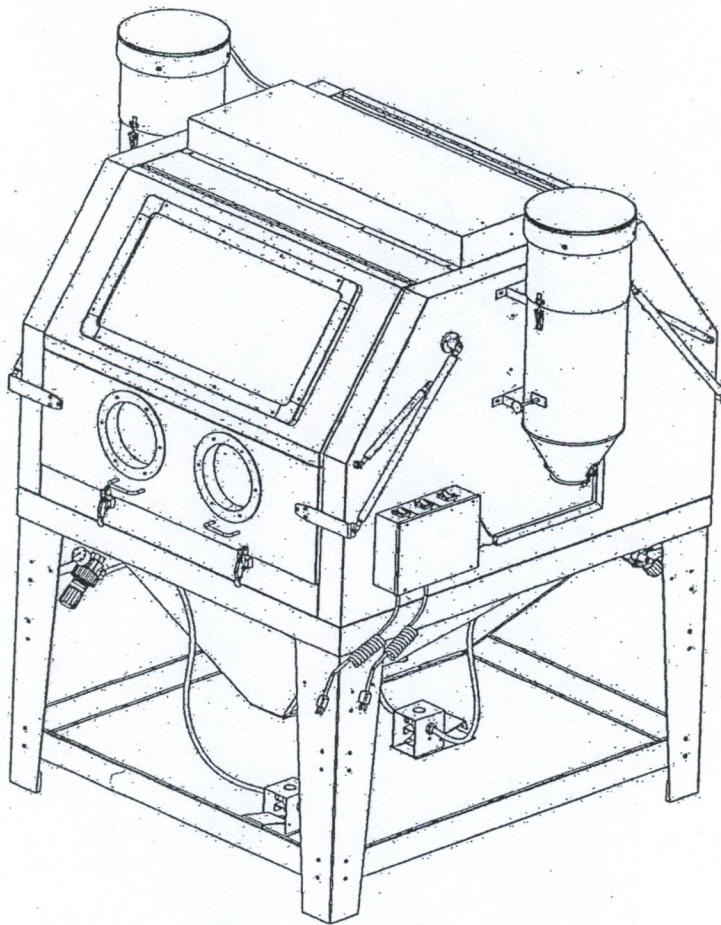

DUAL STATION ABRASIVE BLAST CABINET

41200

OPERATING AND MAINTENANCE INSTRUCTIONS



S & H industries Inc.

5200 Richmond Road,

Cleveland, OH 44146

1-800-253-9726

216-831-0550

service@shindustries.com

www.shindustries.com

CONTENTS

1. TECHNICAL SPECIFICATIONS	Page 1
2. IMPORTANT WARNING PAGE	Page 2-4
3. STARTUP PREPARATION	Page 5
4. ASSEMBLY INSTRUCTIONS	Page 6-12
5. OPERATION INSTRUCTIONS	Page 13-14
6. MAINTAIN SUCTION EFFICIENCY WITH SIMPLE STEPS	Page 15
7. CABINET PARTS DIAGRAM & PARTS LIST	Page 16-18
8. WIRING DIAGRAM	Page 19
9. DUST COLLECTOR PARTS LIST & DIAGRAM	Page 20

Technical Specifications

Rating: 100~120V, 50/60Hz, 1200W

Maximum Work Pressure 110 PSI

Air Consumption: Single operator = 15 - 20 CFM @ 80 PSI

Dual operator = 30 - 40 CFM @ 80 PSI

Work light: Fluorescent light: 4pcs Bulbs

Each dimension: 5/8" x 35-3/64"

Each rating: 110~120V, 60Hz, 26W

Motor Rating: 110~120V, 60Hz, 1200W

Overall Dimensions: 69-3/4" W x 55-1/4" D x 74" H

Net Weight: 462 LBS.

Gross Weight: 540 LBS.

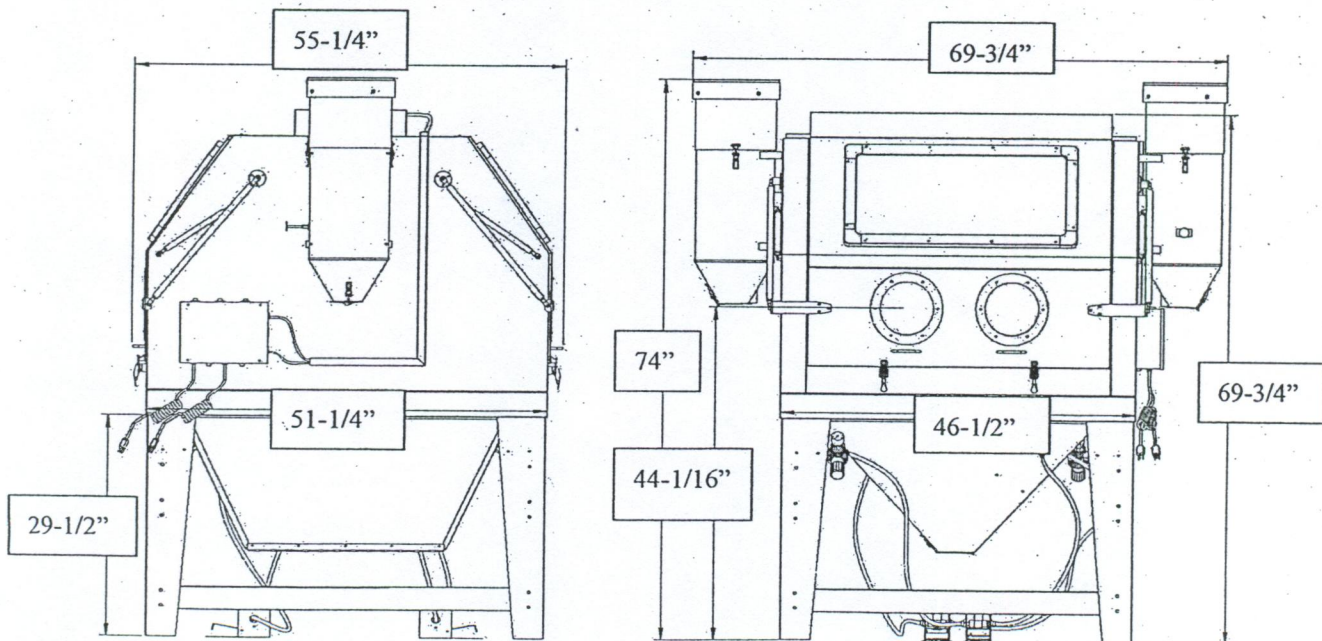



IMPORTANT WARNINGS !

Do not use an Allsource Cabinet Blaster until you have read this manual and you understand its contents and warnings. These warnings are included for the health and safety of the operator and those in the immediate vicinity. Keep this manual for future reference.

Dust created by power sanding, sawing, grinding, drilling, and other construction activities may contain chemicals known to cause cancer, birth defects or other reproductive harm and respiratory illnesses. Some examples of the chemicals include:

- Lead from lead based paints
- Crystalline silica from bricks, cement and other masonry products
- Arsenic and chromium from chemically-treated lumber

Your risk from these exposures varies, depending on how often you do this type of work. To reduce your exposure to these chemicals: Work in a ventilated area, and work with approved safety equipment, such as those dust masks that specially designed to filter out microscopic particles.

Abrasive blasting produces harmful dust. Everyone in the blasting area must wear a properly fitted and properly maintained NIOSH approved respirator.

SILICOSIS AND OTHER DUST WARNINGS:

DO NOT USE SAND!

Breathing dust from silica sand may cause silicosis, a fatal lung disease.

Breathing dust during blasting operations may also cause asbestosis and/or other serious or fatal diseases.

A NIOSH-approved, well maintained abrasive blasting respirator must be used by anyone blasting, anyone handling or using media containing toxic substances or media with free crystalline silica and anyone in the area of the dust. Harmful dust can remain suspended in the air for long periods of time after blasting has ceased, causing serious injury or death.

Before removing respirator, use an air monitoring instrument to determine if atmosphere is safe to breathe. Contact local OSHA or NIOSH office to determine the proper respirator for your particular application.

Air supplied respirators do not remove or protect against carbon monoxide (CO) or any other toxic gas. Use a carbon monoxide removal device and monitoring device with the respirator to ensure grade D quality air. Follow all applicable OSHA standards and OSHA regulation 1910.134 (d).

CABINET BLASTER SAFETY PROCEDURES

CAUTION: READ THESE SAFETY PROCEDURES IN THEIR ENTIRETY -

PARTS OF THE OPERATING INSTRUCTIONS ARE WITHIN THESE WARNINGS.

These procedures are not intended to be exhaustive due to the many variables in the abrasive blasting field. Therefore, we **INSIST** that the hands, ears, mouth, nose and eyes be covered with appropriate safety protection at all times.

ADDITIONAL WARNINGS!

CAUTION MUST BE EXERCISED BY USER AT ALL TIMES

Everyone in the blast area including the equipment operator should correctly use and maintain a NIOSH approved respirator, even after blasting has ceased.

Harmful dust can remain suspended in the air for long periods of time after blasting has ceased causing injury or death.

Before using the abrasive blaster: Put on safety glasses, and NIOSH approved respirator. Always wear these protective items when operating and while servicing your abrasive blaster. A well maintained blasting respirator must be used by anyone blasting.

For safe operation, perform recommended preventive maintenance on blaster cabinet, and accessories. Replace all worn parts before they fail. Immediate replacement of worn components is required. Failure to replace worn components could result in exposing the operator or bystanders to high speed media and compressed air, causing serious injury.

Do not use corrosive materials of any type in unit. Use only clean, dry media.

Static electricity can be created by the use of this equipment. Do not use within fifty feet of any explosive, potentially explosive substances, or their vapors as an explosion can occur.

Do not use this equipment in any area that might be considered hazardous or where flammable gases or liquids are present. Failure to do so may cause an explosion resulting in serious injury.

READ ALL INSTRUCTIONS BEFORE USING THE EQUIPMENT.

SAVE THESE INSTRUCTIONS FOR FUTURE REFERENCE. Due to continuing improvement, Actual product may differ slightly from product described herein.

Remember

1. START UP PREPARATIONS:

- The air supply line should be a minimum 1/2" I.D. ALL HOSES SHOULD BE RATED AT LEAST 125PSI (8.6Bar) and a shut off valve should be installed so that supply air can be turned off and the disconnected from the abrasive blast cabinet for servicing.
- The air supply should be dry and clean from oil and other contaminants.(i.e. use air dryer, coalescent filter, or moisture separator as needed.)
- Blast machine must be grounded to avoid shock.
- Electric extension cords should be three wire grounded (wire size can not be smaller than 3x1.5mm²)

2. Operator's responsibilities before starting:

- Inspect fittings and hoses for damage and water
- Check the seal on all doors. Only operate the blast cabinet with all doors securely closed and dust collection system running.
- Clean dust from dust collector and clean filter as needed.

3. Caution

- Do not use any media containing free crystallized silica. **Do not use sand.**
- Unless special specified, working pressure of blast cabinet and related components must not exceed 110PSI.
- Keep blast nozzle controlled and aimed at the work.

4. Maintenance

- Keep your machine in good repair. Use original parts and do not substitute or modify original supplied items.

Important notice

To distributors, purchasers and end users for using products safely.

The provided information described and illustrated in this material is intended for experienced, knowledgeable users of abrasive blasting equipment and supplies (products).

The products described in this material may be combined as determined solely by the user in a variety of way and purposes. However no representations are made as to be intended to use, performance standards, engineering suitability, safe practices or compliance with government regulation and laws that apply to these products, products of others, or a combination of various products of third parties, and a combination of various products chosen by the user or others. It is the responsibility of the users of these products, products of third parties, and a combination of various products, to exercise caution and familiarize themselves with all applicable laws, government regulations and safety requirements.

No representations are made on intended to the useful life, maintenance cycles, efficiency or Performance of the referenced products of any combination of products.

It is the responsibility of the user to insure that proper and comprehensive training of operators has been performed and all environmental and safety precautions observed.

Assembly instructions

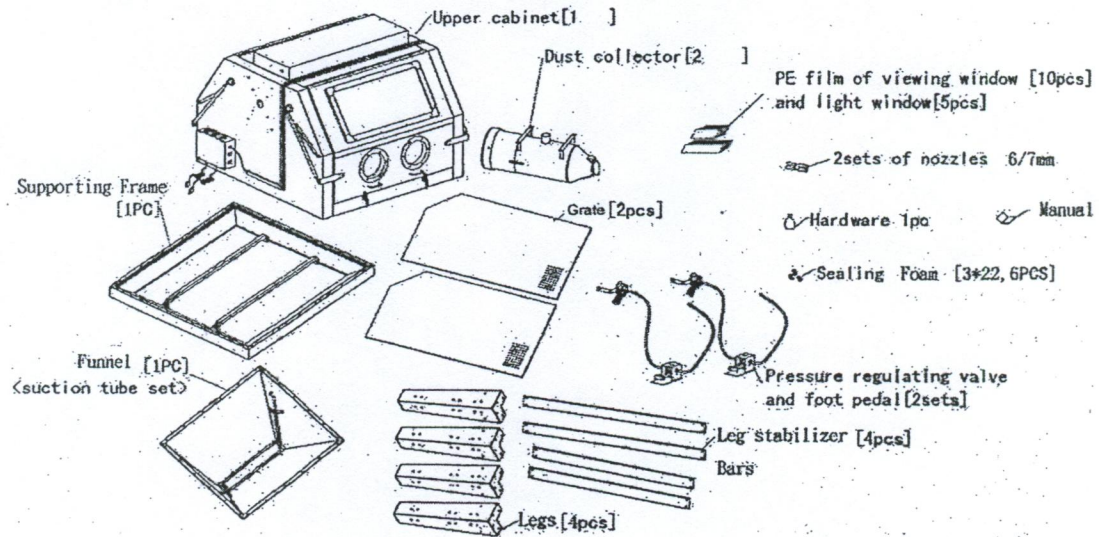

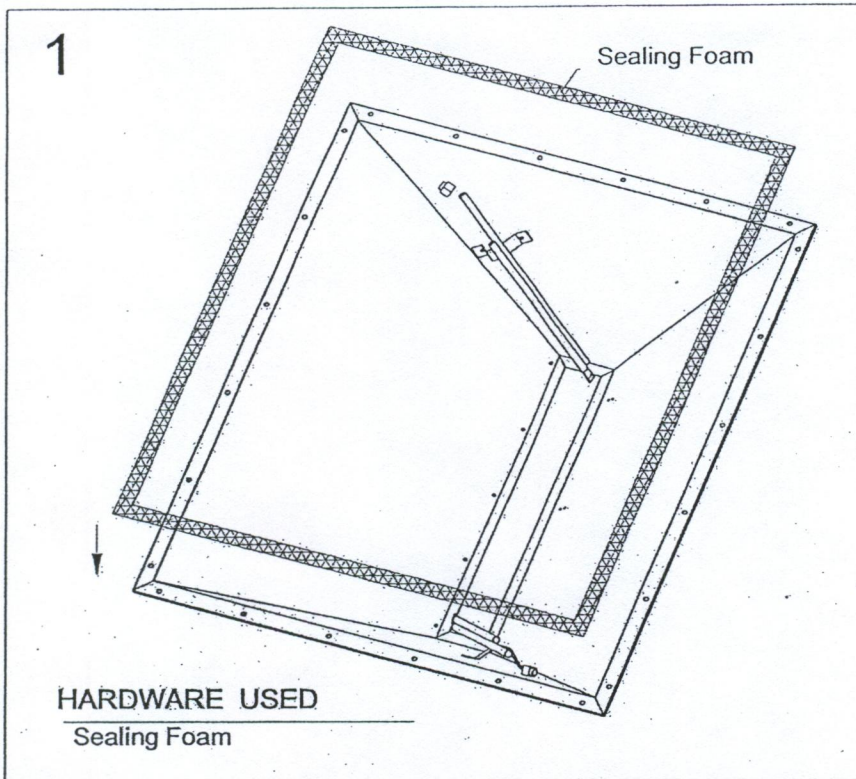

STEP <1>

As shown, with sealing foam installed on the funnel;

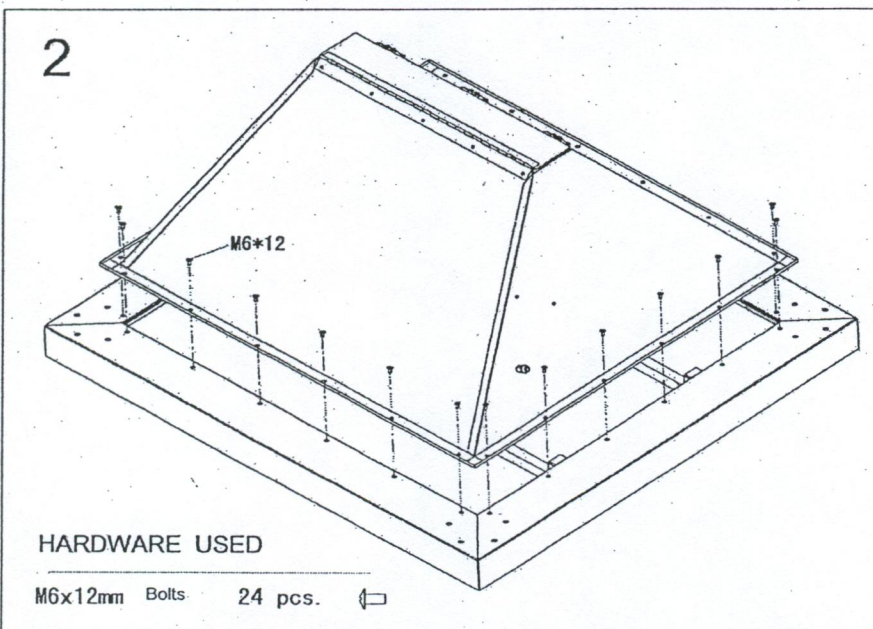

STEP <2>:

As shown, the supporting frame upside down, the funnel is installed on the supporting frame with M6*12 bolts.

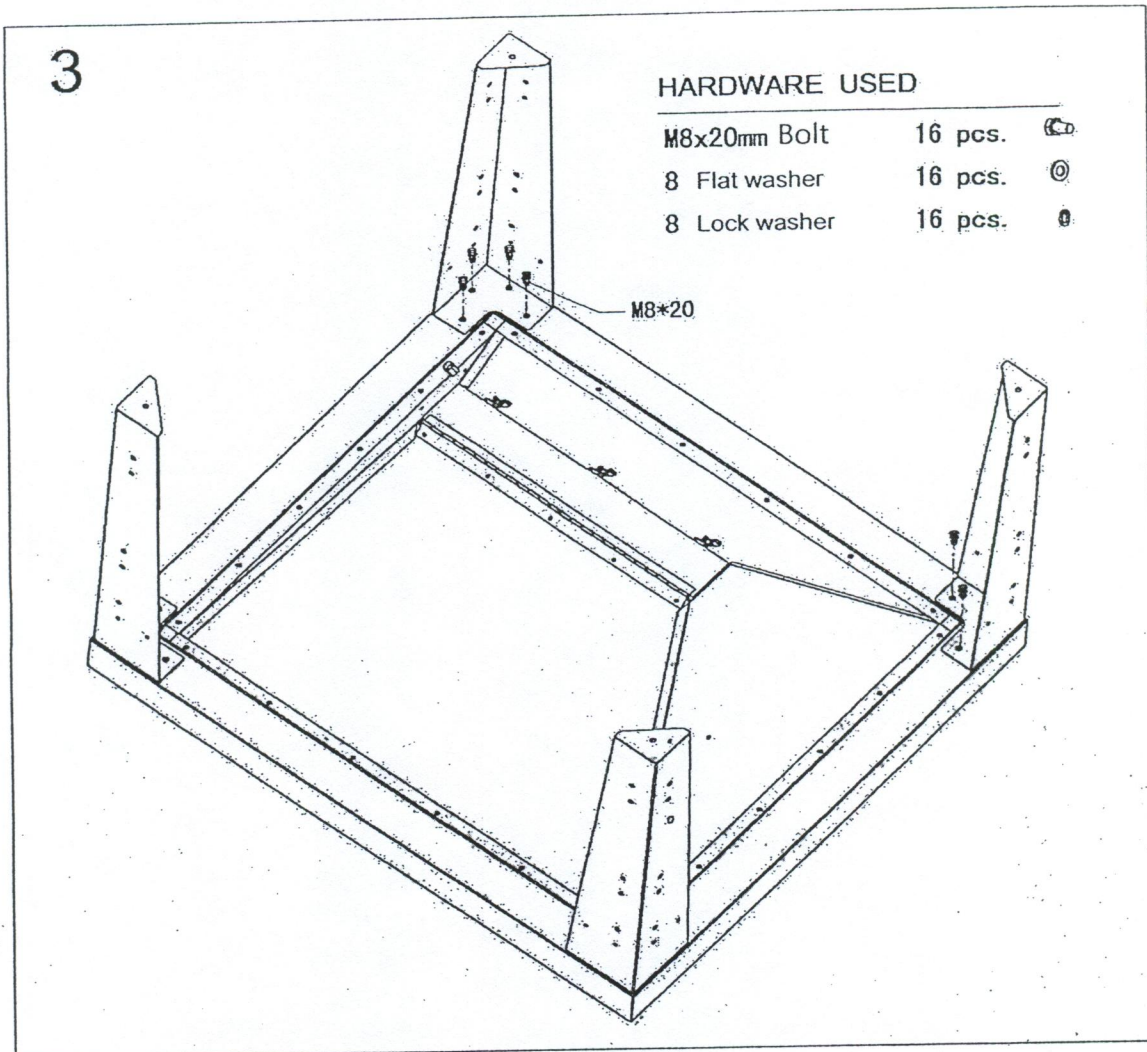





Step<3>:

As shown, the 4pcs legs are arranged on the supporting frame with M8*20 bolts, lock washers and flat washers.

4

HARDWARE USED

M8x20mm Bolt	16 pcs.	
8 Flat washer	32 pcs.	
8 Lock washer	16 pcs.	
M8 nut	16 pcs.	

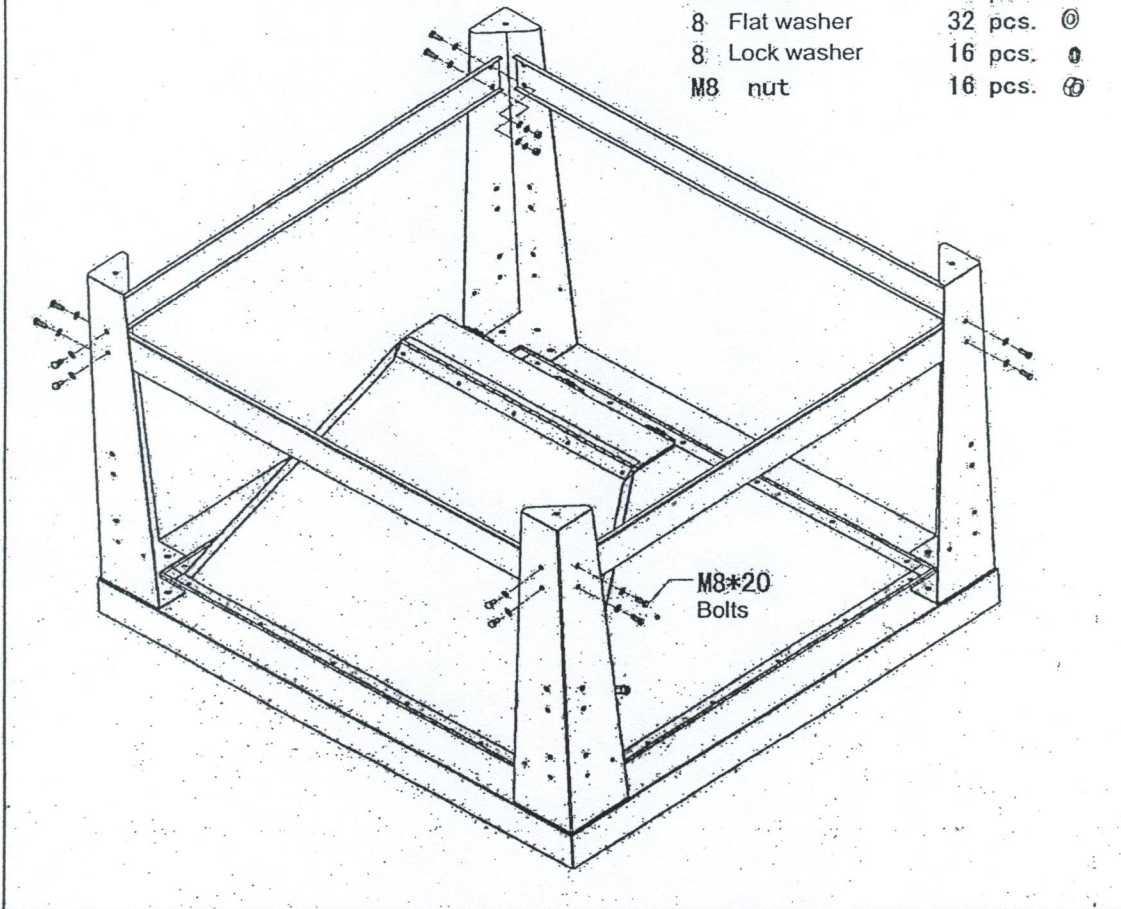

Step<4>:

As shown, the 4 stabilizer bars are installed on the legs with M8*20 bolts, lock washers, flat washers, and nuts.

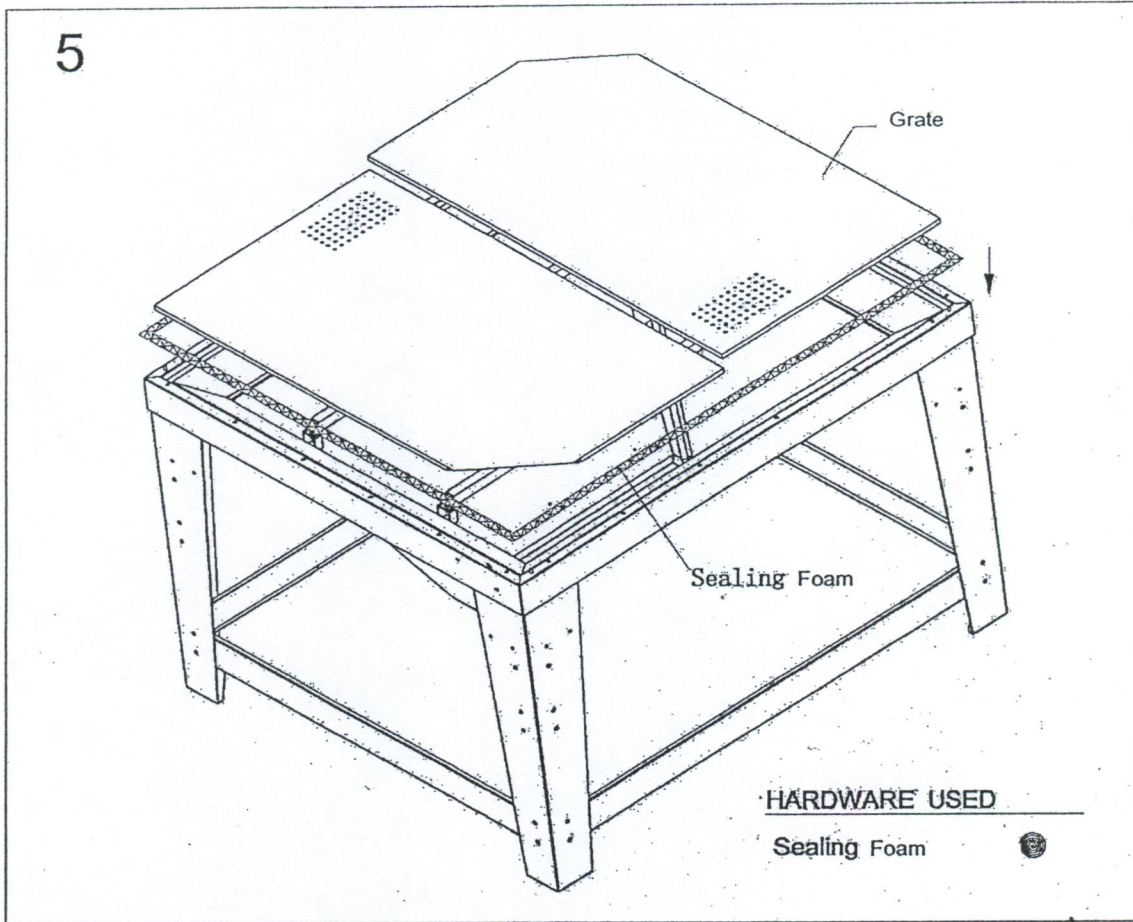

Step<5>:

As shown, the supporting frame over the hole center, with sealing foam install the two grates.

6

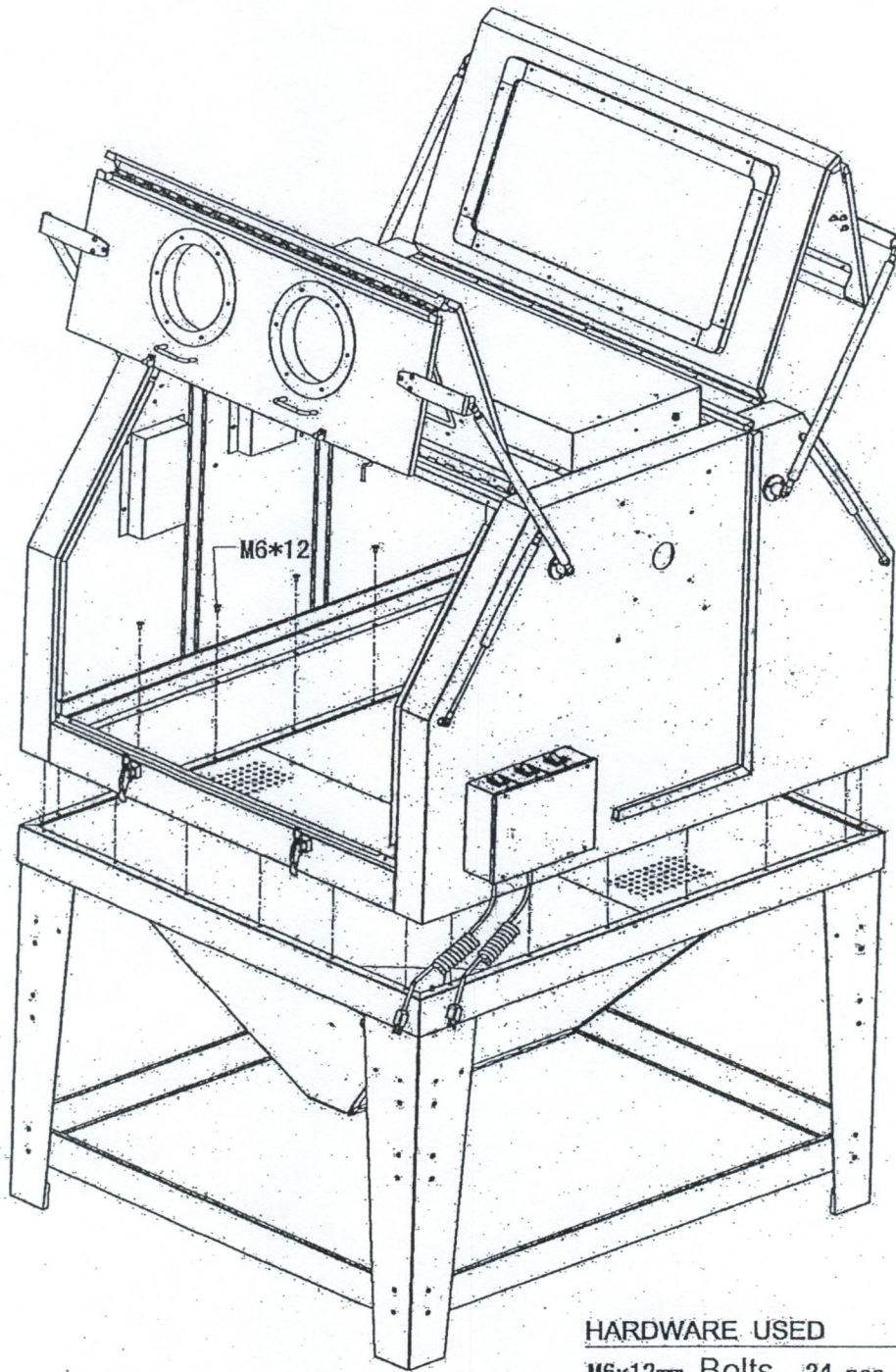

HARDWARE USED

M6x12mm Bolts 24 pcs. ☐

Step<6>:

As shown, install the upper cabinet on the supporting frame, open the double folding doors, and attach to the supporting frame with M6*12 bolts.

7

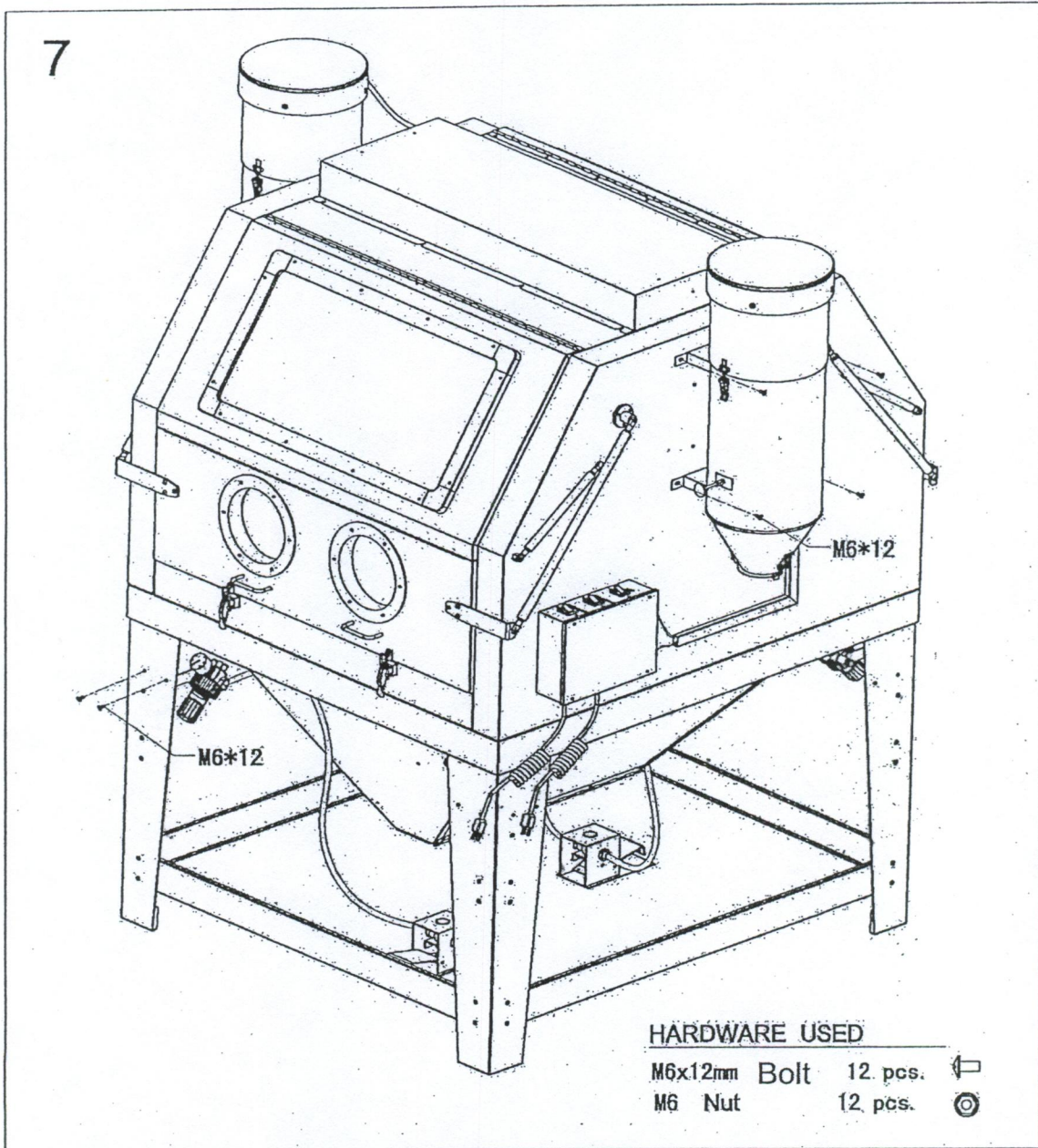

Step<7>:

As shown, the pressure regulating valve is installed on the legs with M6*12 bolts, and nuts. The orange hose on the foot pedal is connected to the large funnel right side hole, and then the abrasive blasting gun, the other end is connected with a abrasive suction pipe (as shown on the next page.)

Install the dust collector plugs to the switch box.

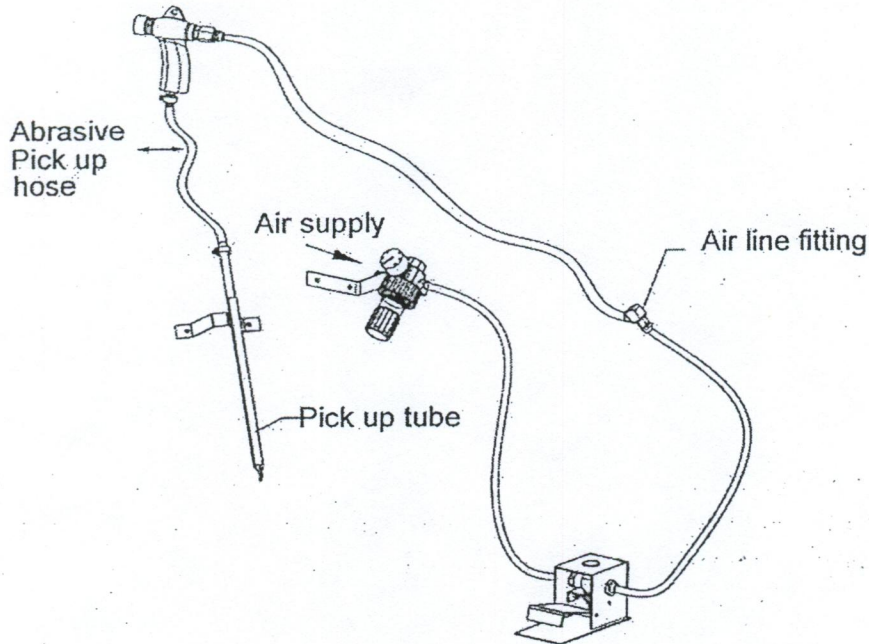

Install air line fitting to blast cabinet funnel. Attach pick up hose to pick up tube
Connect airline to blast gun.

Operating instructions

1. Preparing parts for blasting

All parts processed must be free of oil, grease and moisture. Make sure parts are dry before putting into the cabinet for cleaning.

2. Air pressure

Operating pressure: from 80 to 110 PSI (pounds per square inch) higher pressure, up to 110 PSI can be used, but higher pressure can fracture abrasive prematurely.

- Set air pressure to 80 PSI; most parts for blast cleaning can be blasted at 80 PSI for light gauge steel, aluminum, and other more delicate parts, start at lower pressure and then gradually increase the pressure until the desired finish is achieved.

Warning !

Do not connect to high pressure bottle gas, rupture and explosion can occur.



3. Gun angle and distance

Direct gun at parts at 45-60 degree angle with ricochet towards the back of the cabinet. Do not hold gun at 90 degree angle to parts being processed. This will cause the media blast to

bounce back into the blast stream and slow blasting action. Also 90 degree angle will cause excessive wear on gun and viewing window. Hold gun approximately 6 inches from parts being blasted.

Warning:

Gun must always be pointed away from the operator and towards items being processed. Never blast with any of the cabinet doors open. No one should be at an operator station while loading and unloading parts.

4. **Abrasives:**

- Abrasive should be of good quality and dry. Moisture will cause abrasive not to flow and will create clogging and during problems in the blast cabinet system.

5. **Nozzle size:**

- By changing to the next larger size of nozzle. Production can increase significantly. Larger size nozzles produce a large cleaning pattern. This, however, requires more air (your compressor must be able to provide this) Nozzle size needs to be 3-4 times larger than the abrasive being used.

Maintenance instructions

1. **Blasting gun:**

- After 1-2 hours of blasting time, the nozzles should be checked. If it shows uneven wear it should be turned 1/4 turn every 1-2 hours of use to extend nozzle life.

2. **Caking of abrasive:**

- Abrasive caking is caused by moisture in the air supply or from oily and greasy parts. If this is not corrected media will not flow evenly and will plug up in the pickup tube and the gun. Check air supply; if water is present installed a good moisture trap. If oily or greasy parts are being blasted, you should degrease and dry the parts first.

3. **Reverse pressure:**

- If abrasive stops flowing occasionally, cover the nozzle (hold tight) and push foot pedal down for a couple of seconds. This will cause the system to back blast through the gun and up the media hose. This will help loosen any clogs.

4. **Air pressure drop:**

- Set the air pressure to 80 psi on the air gauge at regulator. Push the foot pedal while holding gun and see if the gauge pressure drops significantly. If the pressure drops, this indicates that there is a restriction in the supply line. This could be that hose is too small, a reducer or quick coupler, a plugged filter, or other piping that doesn't allow enough air through. Also if the cabinet is too far from the air compressor, a pressure drop will occur. Air supply line should be 1/2" or larger.

5. **Poor visibility-excessive dust:**

- The air inlet should be free of restrictions to allow air into cabinet.
- The dust collector is full and needs to be cleaned and emptied.
- Dust filter is contaminated. Clean the dust collector filter as needed every 1-2 hours of operation. Replace filter if unable to clean thoroughly.
- Abrasive breakdown, eventually the abrasive becomes so small that it is essentially dust.

6. Poor visibility-viewing window:
 - Viewing windows come with a clear plastic protector on them. As these become pitted they can be easily replaced to extend the life of the window. The window can also be easily replaced.
 -
7. Poor media flow:
 - Check for moisture as indicated above. Install moisture trap as needed, replace damp media and clean hoses, pick up tube and funnel thoroughly.
 - Holes in media hose will cause poor media delivery. Replace hose.
 - Debris in abrasive. Replace or screen media.

Maintain suction efficiency with simple steps:

The most common problem customers have with their abrasive blast cabinets is a decrease in production rates. A properly maintained blast cabinet should provide years of constant service. When production rates fall the operator can usually locate the problem by checking:

1. Air supply:
 - If the pressure gauge on the regulator shows an adequate no-load supply (when the blaster is not running), press the foot pedal. If the pressure drops more than a few psi your air supply is restricted or inadequate. Clean filters and moisture separators all the way back to the air compressor. Straighten any kinky lines. Use a master gauge to check the air pressure or replace existing gauge if you suspect it is giving you false readings.
2. Blast gun:
 - The nozzle will wear out eventually. Replace it if it's measured 1/16" over its original size or if it shows uneven wear. Adjust as needed for different media and conditions. A properly working gun will pull 9-13 inches of vacuum on a manometer.
3. Dust collector:
 - Inadequate cabinet ventilation results in reduced cleaning power at the nozzle as well as diminished view of the work in progress. Use the dust collectors shake every 20-30 minutes when the cabinet is turned off, more often in dusty conditions. Empty dust collector at least once a day. Remove filter and blow out occasionally to keep the dust collector or vacuum working efficiently. Replace as needed.
4. Media:
 - Use quality blasting abrasive correctly sized to the job. Damp to dirty abrasive can bring blasting to an instant halt. Store media in a dry area and load the appropriate quantity. Add enough media through the grate to have 6" deep of abrasive or more to cover the bottom of the pickup tube. If you run out of media as you are blasting add enough so it keeps circulating to the gun. The abrasive will eventually breakdown or get too contaminated to use. **Do not use sand!**

5. Media delivery:

Replace any abrasive hose that has soft spots or visible wear. Slight adjustments can be made to the air jet to help increase vacuum.

Parts Diagram

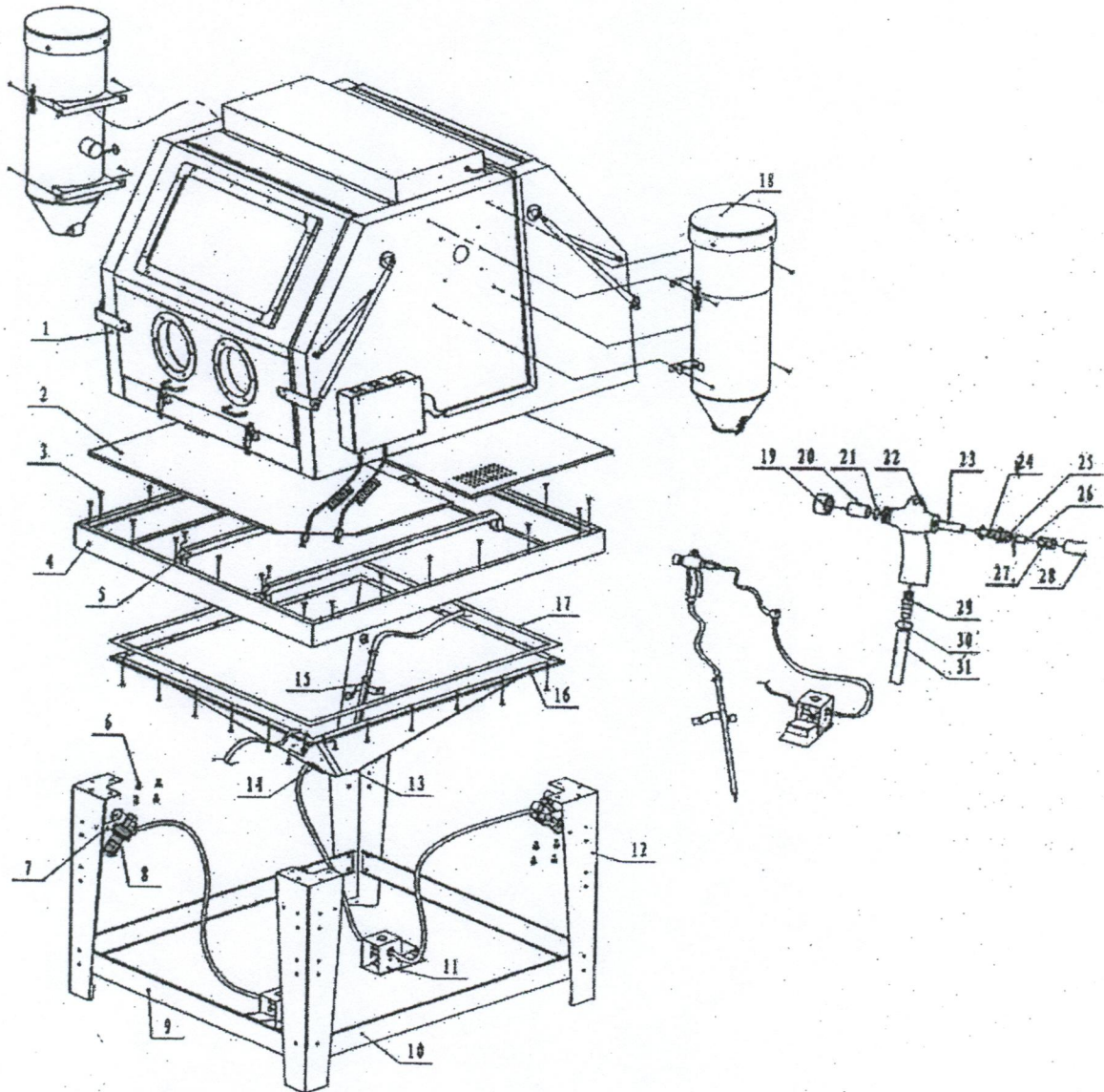

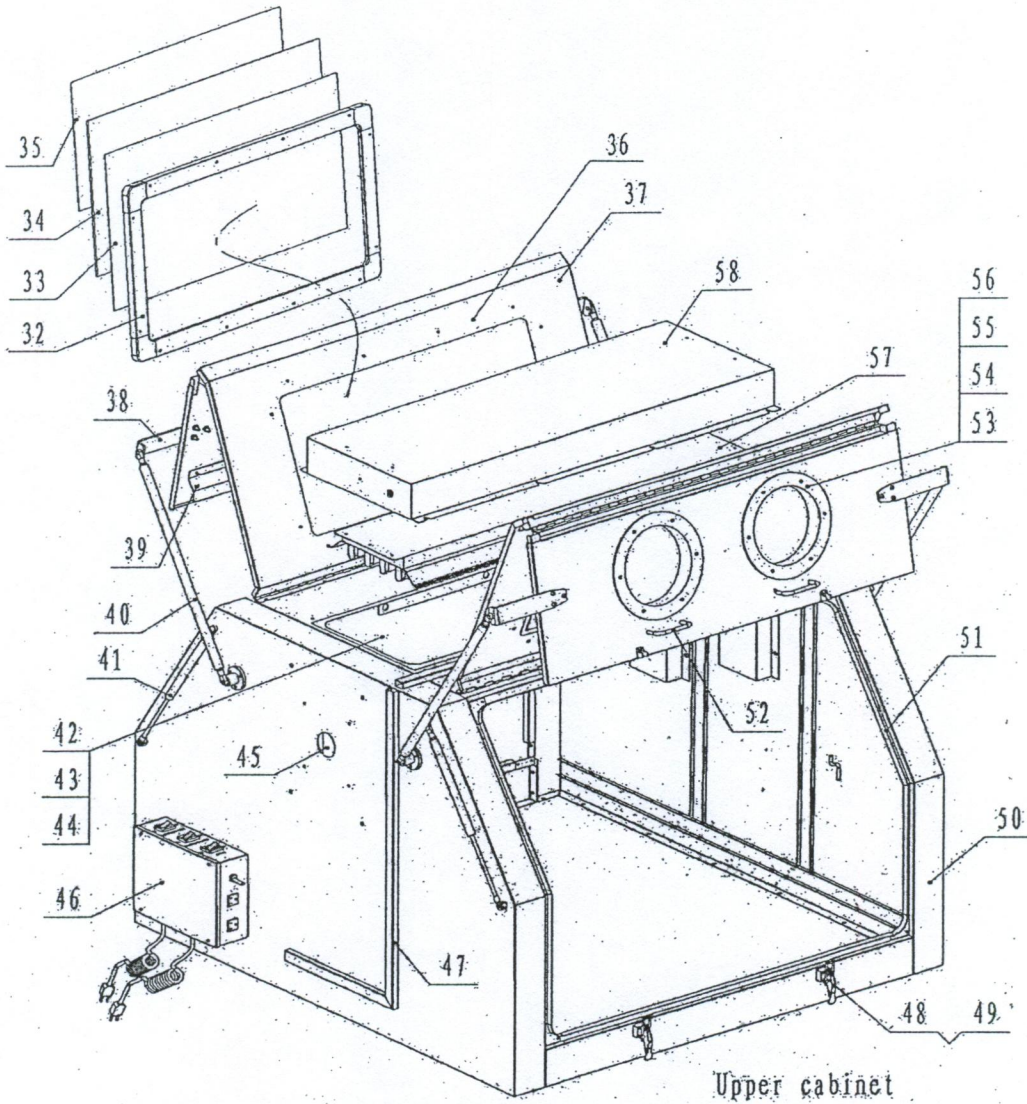

Parts Listing

1	Upper cabinet	1
2	Steel grate	2
3	Bolts M6X12	62
4	Supporting frame	1
5	Supporting tubes for steel grate	2
6	Bolts- M8X20	32
7	Air regulator bracket	2
8	Air regulator with pressure gauge - 4150009	2
9	Leg stabilizers	2
10	Leg stabilizers	2
11	Foot pedal - 4150011	2
12	Legs	4

13	Abrasive door	1
14	Abrasive door latch	3
15	Pickup tube	2
16	Funnel	1
17	Sealing foam – 10793 sold per foot	1
18	Dust collector - 4150063	2
19	Nozzle holding nut - 4150042	2
20	NOZZLE - 4150046 (6mm) or 4150047 (7mm)	8
21	O-Ring , nozzle - 4150048	2
22	Gun body - 4150049	2
23	Air jet sleeve - 4150051	2
24	Lock nut - 4150050	2
25	Air jet with sleeve - 4150052	2
26	Airline fitting	2
27	Airline connector	2
28	Air hose - 41856	6
29	Air fitting- 4150054	2
30	Hose clamps	4
31	1/2" abrasive hose - 41859	2
32	Window frame cover - 41821	2
33	Outer viewing window - 41822	2
34	Inner viewing window - 41823	2
35	PE film of viewing window - 41824	2
36	Sealing foam of viewing window – 10793 sold per foot	2
37	Front door	2
38	The support bracket for front door	4
39	Abrasive deflector	2
40	Main support poles - 41834	4
41	Support pole, air cylinder - 41835	4
42	Rubber seal on light window - 41829	2
43	PE film of light window - 41830	1
44	Light window - 41829	1
45	Dust collector inlets	2
46	Switch box	1
47	Electrical conduit cover	1
48	Front door latch - 41837	4
49	Latch seats - 41838	4
50	Upper cabinet	1
51	Rubber seal strip of front opening door frame - 41826	2
52	Handle - 41840	4
53	Gloves – 33" x 7"	2
54	Glove ring seat	4
55	Glove ring - 4150020	4

- 56 Glove clamp – 4150014
- 57 Fluorescent lamp/ lamps 4pcs - 41829
- 58 Light cover

4
1
1

WIRING DIAGRAM

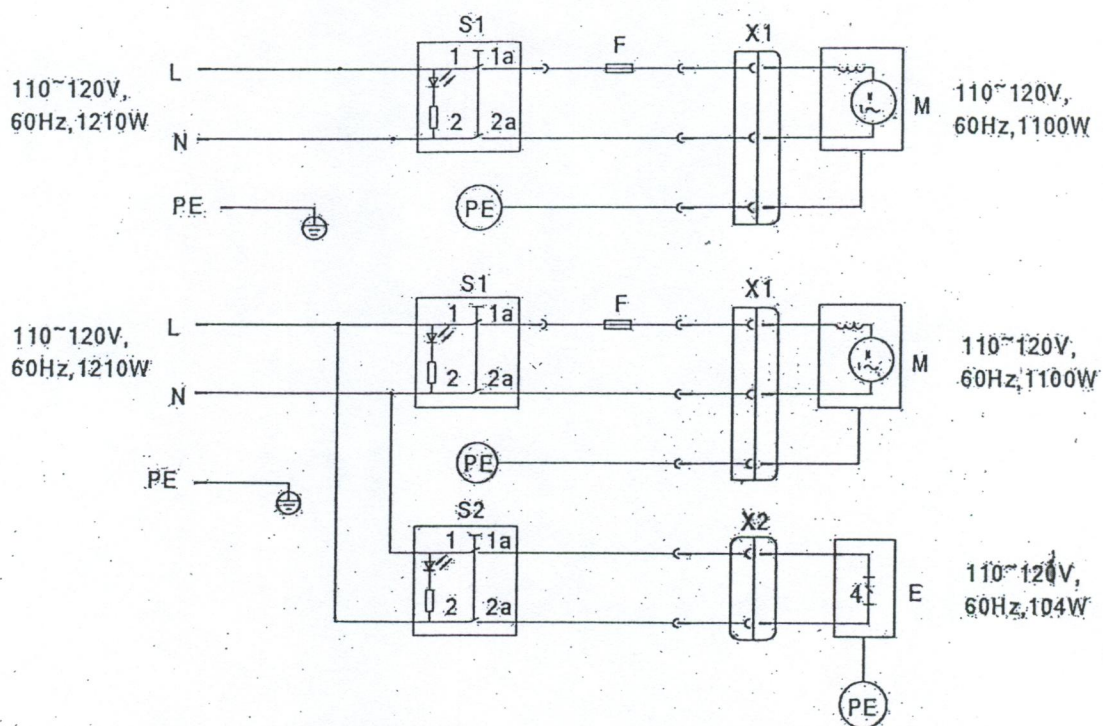

L POWER WIRE
N NEUTRAL WIRE
PE GROUND WIRE
F FUSE
E BALLAST

X1 CONNECTOR
X2 CONNECTOR
S1 LIGHT SWITCH
S2 MOTOR SWITCH
M MOTOR

EXPLODED VIEW OF DUST COLLECTOR

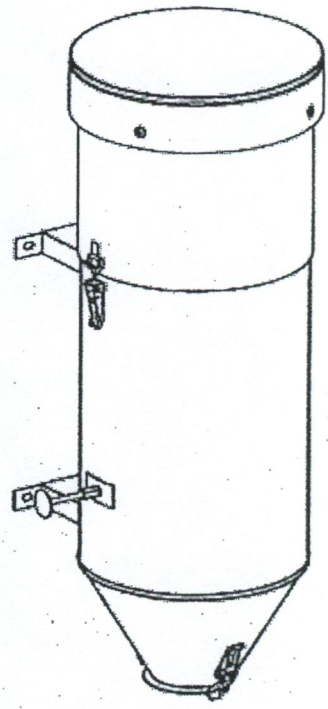
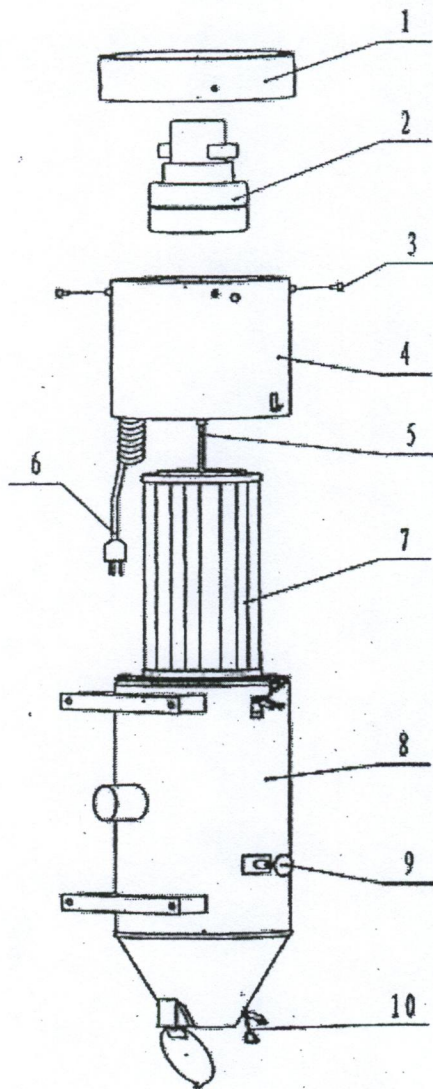

Parts Listing for dust collector

1	TOP OF DUST COLLECTOR	1
2	VACUUM MOTOR - 40287	1
3	BOLT	4
4	MOTOR COVER	1
5	BOLT	1
6	POWER CORD	1
7	DUST FILTER - 4150029	1
8	ROUND DUST COLLECTOR	1
9	PUSH ROD	1
10	LATCH	3